









electronxray.com

iELECTRON
RESEARCH DEVELOPMENT AND PRODUCTION COMPANY

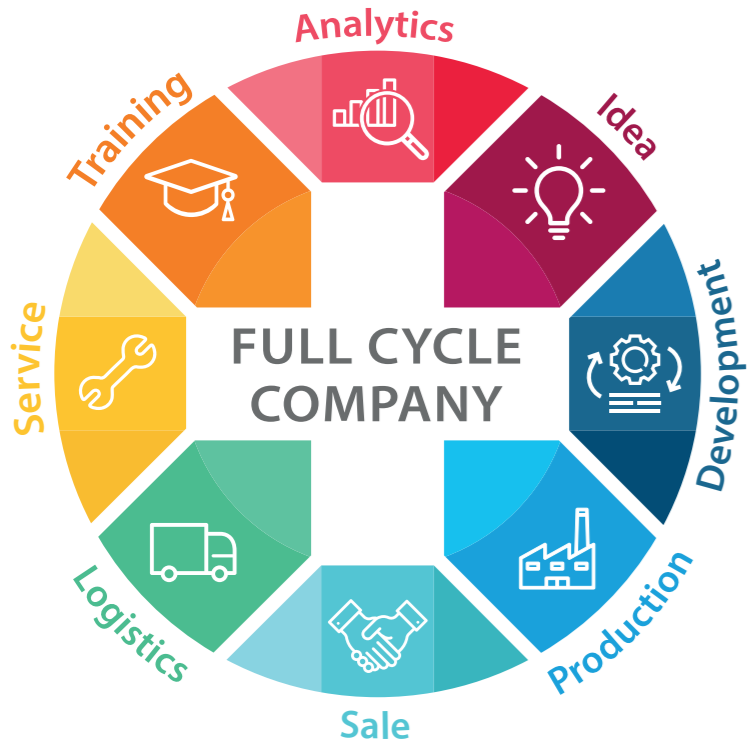

TABLE OF CONTENTS

	About us	• 2
	X-ray diagnostics	• 8
	<ul style="list-style-type: none">• Multipurpose remote-controlled systems• Remote-controlled systems• Versatile X-ray diagnostic systems of Expert class• Digital radiography/fluoroscopy systems• Digital radiography systems• Digital radiography systems with a mobile table• Chest X-ray systems• Mobile radiography systems• Film-screen radiography/fluoroscopy systems	<ul style="list-style-type: none">• 10• 14• 18• 22• 26• 30• 34• 38• 42
	X-ray intervention	• 46
	<ul style="list-style-type: none">• X-ray angiography systems• Mobile C-arm systems	<ul style="list-style-type: none">• 48• 52
	Computed tomography	• 56
	<ul style="list-style-type: none">• Modular CT units• Computed tomography systems• Weight-bearing CT systems	<ul style="list-style-type: none">• 58• 62• 66
	Nuclear medicine	• 70
	<ul style="list-style-type: none">• Nuclear imaging systems (SPECT)	<ul style="list-style-type: none">• 72
	Ultrasound diagnostics	• 76
	<ul style="list-style-type: none">• Ultrasound systems	<ul style="list-style-type: none">• 78
	IT solutions for healthcare	• 82
	<ul style="list-style-type: none">• Data communications system PACS• Central PACS archive• Medical screening• Multimodality diagnostic radiologist's workstation (radiologist's AWS)• Completed projects	<ul style="list-style-type: none">• 86• 87• 88• 88• 89
	Service	• 92



NIPK Electron Co. is a leader of the Russian market in the development and manufacture of medical imaging equipment, integrated and IT solutions for healthcare.



EFFECTIVE SOLUTIONS

- The Company is included in the list of enterprises of the Ministry of Industry and Trade of the Russian Federation exerting a significant influence on the industry and trade in Russia. It is also included in the list of strategic organizations of the medical industry in Russia.
- The equipment manufactured by the Company is included in the Unified Register of Russian Radio-electronic Products.

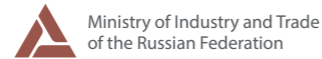

Ministry of Industry and Trade of the Russian Federation



Ministry of Economic Development of the Russian Federation



Ministry of Health of the Russian Federation



Federal Service for Surveillance in Healthcare



MORE THAN **30** YEARS OF EXPERIENCE AND INNOVATIONS



ISO INTERNATIONAL QUALITY STANDARDS

Quality Management System complies with the following standards: GOST R ISO 9001, GOST ISO 13485, ISO 9001, ISO 13485. The products are certified for compliance with the European Medical Device Directive MDD 93/42/EEC.



FOR HEALTHCARE



PRODUCTIVE CAPACITY OF **2 000** EQUIPMENT UNITS ANNUALLY



MORE THAN **5 000** HOSPITALS AND CLINICS IN DIFFERENT REGIONS OF THE RUSSIAN FEDERATION



MORE THAN **60** PATENTS FOR INVENTIONS



OWN MANUFACTURING AREA OF **12 000** M²



SALES TO ALL REGIONS OF RUSSIA AS WELL AS NEIGHBORING AND FAR COUNTRIES



MAJOR SUPPLIER FOR THE RUSSIAN GOVERNMENT NEEDS



WORLD-CLASS UNIQUE R&D PRODUCTS



RAPID SERVICE RESPONSE COMPANY



THE LEADER THAT DEVELOPS MEDICINE, SCIENCE, AND TECHNOLOGIES

HISTORY OF LEADERSHIP

NIPK Electron Co. is **No. 1** in Russia

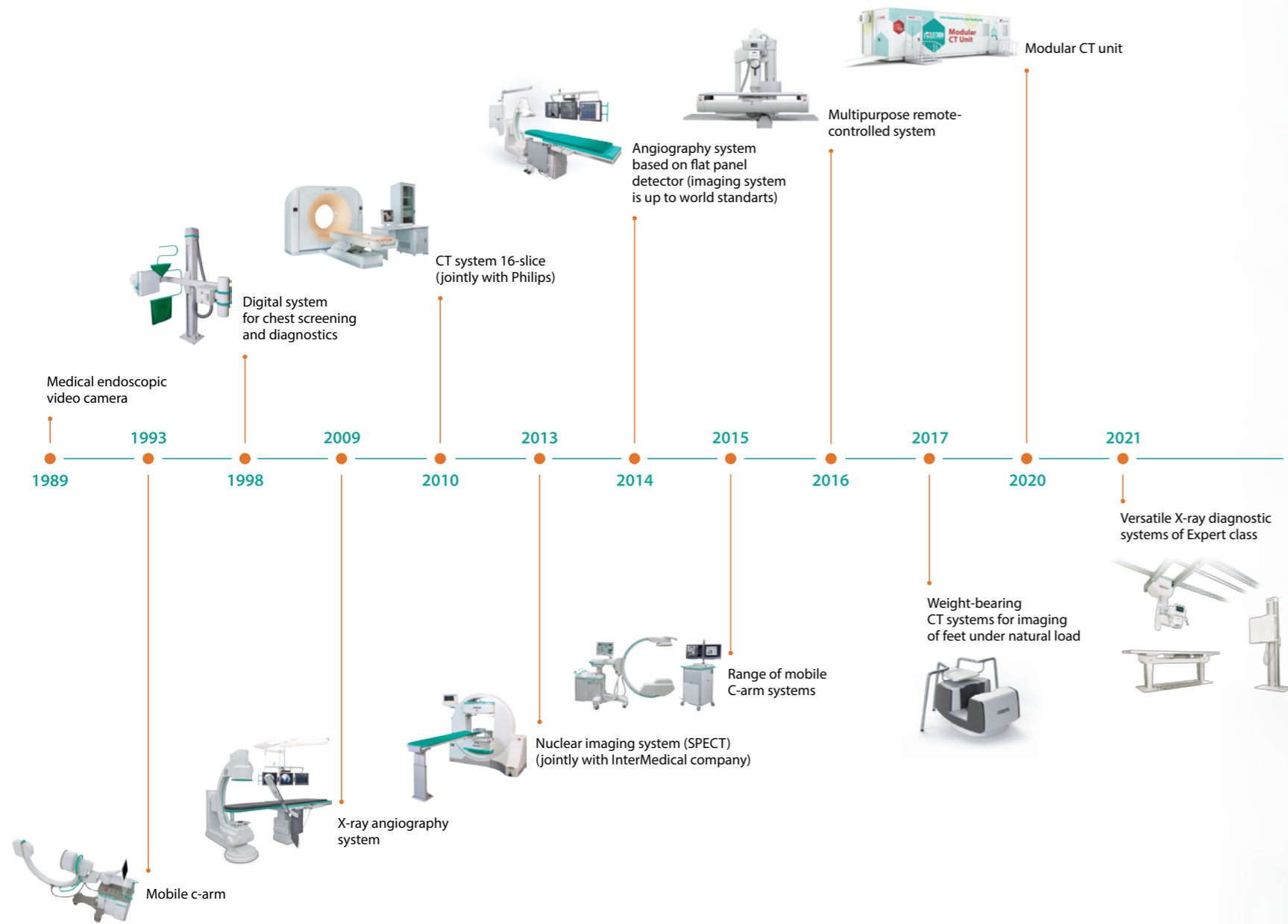

INTEGRATED SOLUTIONS FOR HEALTHCARE



PRODUCT PORTFOLIO

WIDE RANGE OF EQUIPMENT



X-ray diagnostics

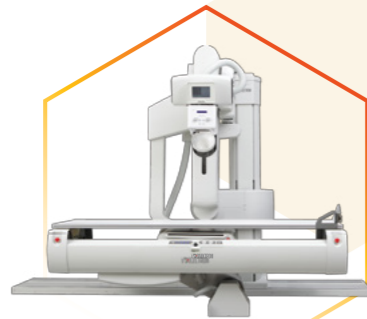

Multipurpose remote-controlled systems



Remote-controlled systems



Radiography/fluoroscopy systems



Versatile X-ray diagnostic systems of Expert class

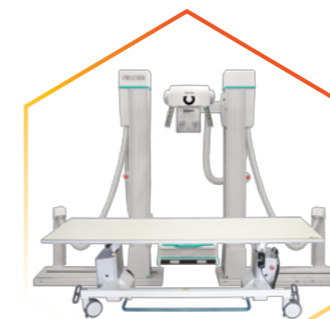

Digital radiography systems with a mobile table



Mobile radiography systems

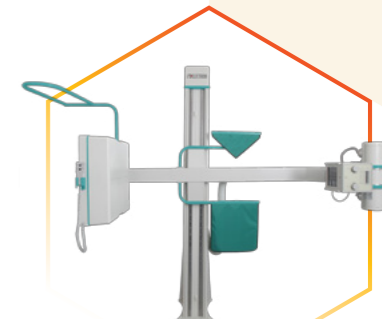

Chest X-ray systems



Computed tomography

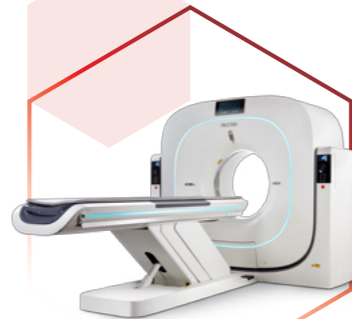

Computed tomography systems



Modular CT units



Weight-bearing CT systems



X-ray intervention

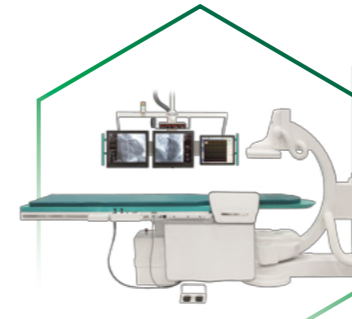

X-ray angiography systems



Mobile C-arm systems



Nuclear medicine



Nuclear imaging systems (SPECT)



IT solutions

Integrated informational support of the clinical diagnostic process



Ultrasound diagnostics



Ultrasound systems



Support service

Professional installation, maintenance and repair of medical equipment in all Russian regions



X-ray diagnostics





MULTIPURPOSE REMOTE-CONTROLLED SYSTEMS



The versatile, fully automated system with a multi-functional fluoroscopy tilting table for multipurpose examinations ART is an essentially new tool of X-ray diagnostics with no analogues in the world, which opens up the maximum functional possibilities for users.

The multipurpose remote-controlled system is designed taking into consideration the needs of a wide range of radiologists based on the detailed analysis of the systems available on the world market and offers of the leading Russian experts in the field of diagnostic imaging. The system can be used instead of several other machines as it provides a wide range of diagnostic opportunities and allows performing various X-ray diagnostic examinations, in particular:

- Contrast-enhanced imaging of the gastrointestinal and genitourinary organs
- X-ray examinations of the thoracic organs and musculoskeletal system from the extremities up to the skull
- Interventional radiology procedures

The unique system design provides for operation in any required mode: radiography, fluoroscopy, linear tomography, and with any necessary patient's position (lying on the table or trolley including that in the lateral position, in the sitting or the upright position). The multipurpose X-ray tube stand moves around the patient making it possible to diagnose different injuries and diseases in any mode and at any angle from the patient's head to feet. This is of special significance in case of emergency examinations because it allows avoiding any additional injury and provides for rapid obtaining of important diagnostic data to ensure selecting the optimal treatment strategy.

The ART is equipped with a modern imaging system based on a large format dynamic flat panel detector that ensures the highest quality of obtained digital images.



A unique fluoroscopy processing system makes it possible to record a whole series of images or any fragment both remotely and directly at the X-ray table.

In addition to standard modes, the ART system features several progressive technologies in the field of image obtaining and processing such as:

- Tomosynthesis, which is a modern method of X-ray examination based on slice tomography image reconstruction of the whole examined region from a sequential set of low dose angular views. This technology can be used successfully in diagnostics of pulmonary nodular lesions (including lung cancer), examinations of the musculoskeletal system, contrast-enhanced imaging of the GIT, urinary, etc. It allows not only to reveal the lesion but also ensures the determination of its accurate localization.
- Stitching: this method makes it possible to obtain and combine several images to create a panoramic view of the vertebral column or long bones during one examination in automatic mode what is very relevant when diagnosing musculoskeletal disorders, the degree of scoliosis as well as when planning surgical treatment.

The control system allows positioning the tube stand and performing the examinations completely remotely; in this situation, an X-ray technician can check the patient's position using a video camera built-in in the collimator. The maximally flexible user interface of the control system allows a radiologist or a radiology technician to select the convenient settings, generate their own APR programs; set up the tomography parameters along with many other things.

If necessary, technical solutions used in the ART system allow implementing a remote connection in the online mode to diagnose and remove faults, and also set up the system according to user's demands.

Benefits

Mobility and multifunctionality

- The widest range of system movement providing for the following:
 - Imaging in lateral position both on a tilting table and a mobile X-ray table
 - Imaging of the upper extremities (the humerus, the elbow joint, hands) directly to the detector
 - Imaging of the lower extremities including weight-bearing foot radiography in lateral view and in dorsoplantar view
 - Imaging in the oblique view on the table edge (imaging of cranial bones in oblique views, Mayer's view, etc.)
 - Chest radiography with the detector positioned either vertically or horizontally
 - Examination of the patient on a mobile X-ray tablet the X-ray transparent gurney, without the need of changing the position
 - Imaging in the tomosynthesis a and stitching modes
- The possibility to set up the angle and the velocity of linear tomography on an individual basis
- The maximum focal distance of more than 200 cm
- Immediate switching between the radiography mode and the fluoroscopy mode

High diagnostic image quality

- State-of-the-art digital imaging system
- Automated program filters for image processing
- High spatial resolution and fluoroscopy rate
- Maximum possible size of the detector active area
- State-of-the-art analysis of examination findings

Easiness, simplicity, and user-friendliness

- Possibility of remote control of all system functions and movements
- Possibility to lower the tabletop to ensure the patient's maximum comfort including that for easy movement from a mobile X-ray table and from a wheelchair
- User-friendly ergonomic remote-control console
- Color touch display
- Multilingual interface
- Individual setup of the control system interface
- Additional control consoles on a fluoroscopy tilting table and a detector
- Possibility to record fluoroscopy, including that in remote mode

Safety and low exposure dose

- Highly sensitive X-ray detector
- Removable grid
- Wide APR program range for patients of various age and body build
- Automatic exposure control (AEC)
- Possibility to perform fluoroscopy examinations while ensuring radiation protection of medical staff
- Video camera built-in in the collimator for the control of patient positioning

Reliability and durability

- Reliable fixed digital detector
- Elaborated and reliable stand design
- The generator uses up-to-date knowledge in the field of voltage stabilization and protection against power surges

Basic configurations*

High voltage generator (HVG)

- from **65 kW**; from **80 kW**

Flat panel detector for radiography and fluoroscopy

- Dynamic flat panel detector
- Light mobile patient table
- Mobile table with elevating and floating tabletop

Mobile patient tables

Specialized appliances for patient positioning

- Removable footrest
- Shoulder-rests
- Compression belt
- Removable handles for the patient
- X-ray transparent step
- Positioning systems of children of various age groups

Automated workstations (AWS)

- Operator's workstation for system control (radiology technician's AWS)
- Workstation for the work with examination findings (radiologist's AWS)
- Additionally:** medical monitors, medical printer, clinician's workstations, operator's workstations, PACS server

Specialized software (SW) for radiology technicians and radiologists

- Operating the patient and image databases
- Special APR programs including those for pediatrics
- Multimodality
- Support of DICOM 3.0 standard
- Image postprocessing
- X-ray dosimetry
- Color X-ray technology

X-ray radiation protective equipment for patients and staff

- X-ray protective clothes for the medical staff
- Personal protective equipment for patients
- X-ray protective windows of different sizes

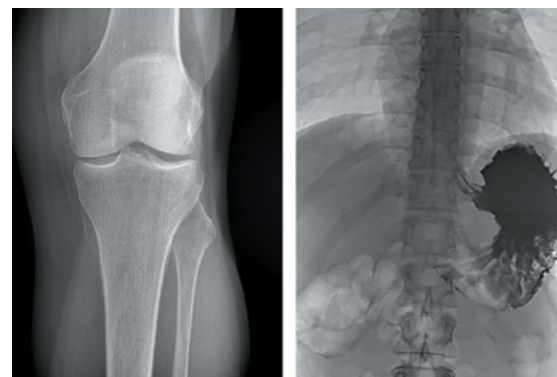
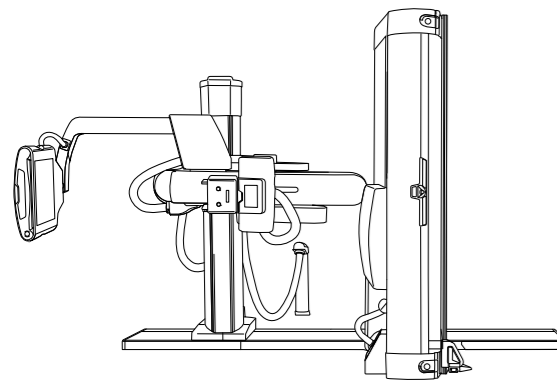
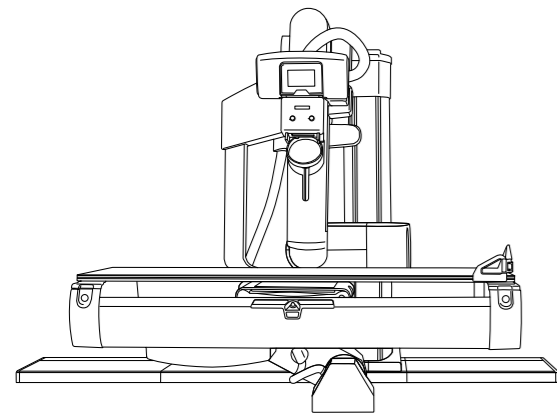

Chest X-ray, posteroanterior view



Chest tomosynthesis, slice height: 53 mm

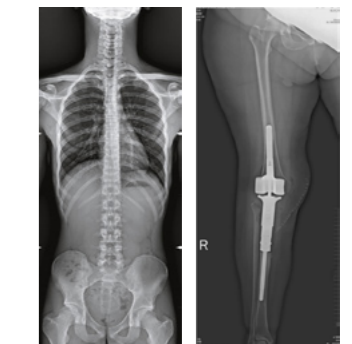

Stitching

* The "Basic configurations" section includes the information only on the most demanded configurations; the general list is significantly wider. Any configuration and technical parameters can be changed by the manufacturer's initiative or at the customer's request.



REMOTE-CONTROLLED SYSTEMS



The remote-controlled system is a compact and versatile X-ray system for diagnostics of disorders of different organs and systems of the human body. The range of remote-controlled systems manufactured by NIPK Electron Co. makes it possible to perform various high-quality investigations, e.g. radiography, fluoroscopy, or linear tomography.

An imaging system based on a modern dynamic flat panel detector allows performing X-ray diagnostics examinations with unsurpassed quality and high accuracy. The high spatial resolution and minimum exposure dose are ensured due to a small pixel size. The absence of geometric distortions, large detector area, and immediate switching of radiography and fluoroscopy modes allow ensuring error-free diagnostic imaging.

All system functions can be controlled remotely from the control room using a color touch display. The multilingual software developed by the engineers of NIPK Electron Co. together with healthcare professionals is installed at the radiology technician's workstation.

Thanks to this, the radiology technician's AWS has the whole range of functions including keeping the patient database, imaging parameter control, image processing functions, automated generation of statistical reports according to the formats adopted in Russia, and many other things.

The examined organ and view are selected using a user-friendly, self-explanatory graphic interface. Depending on the patient's body habitus, a radiologist or a radiology technician can select one of three types for automatic setting up of exposure parameters. Besides, the programs for imaging the adults and children of different ages including infants are saved in the system memory.

If necessary, the technical solutions used in remote-controlled system allow establishing a remote connection online to diagnose and remove faults as well as setting up the system to meet the user's demands.

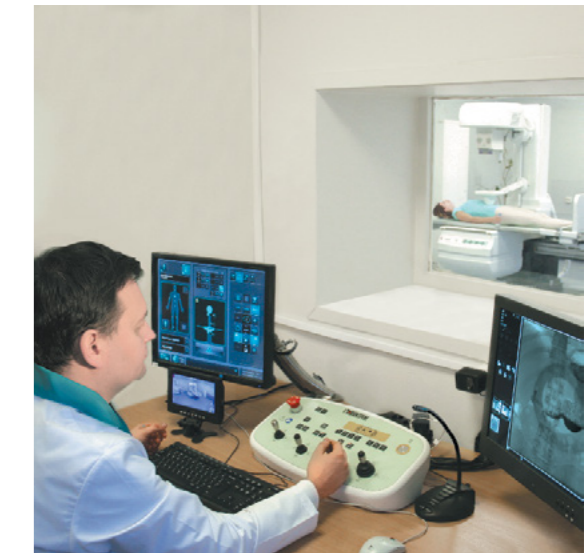

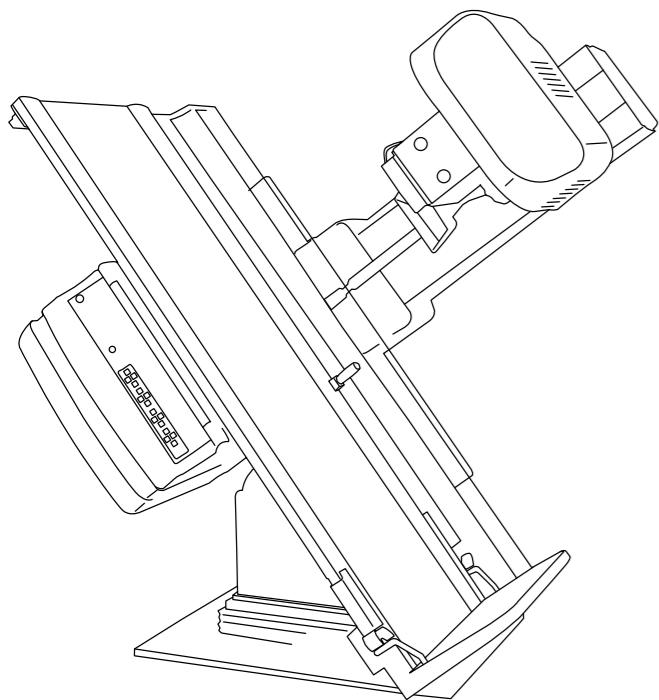

Benefits

- High diagnostic image quality**
 - State-of-the-art digital imaging system
 - Automated program filters for image processing
 - High spatial resolution
 - High fluoroscopy rate
 - Maximum possible size of the detector active area
 - State-of-the-art analysis of examination findings
- Easiness, simplicity, and user-friendliness**
 - Possibility of remote control of all system functions and movements
 - User-friendly ergonomic remote control console
 - Color touch display
 - Multilingual interface
 - Additional control console on the system stand
- Mobility and multifunctionality**
 - The widest range of system movement
 - Possibility to set up the angle and velocity of linear tomography on an individual basis
 - Maximum focal distance of up to 180 cm
 - Immediate switching between the radiography mode and the fluoroscopy mode
- Safety and low exposure dose**
 - Highly sensitive X-ray detector
 - Removable grid
 - Wide APR program range for patients of different age and body build, Automatic exposure control
 - Possibility to perform fluoroscopy examinations not exposing the staff to radiation
- Reliability and durability**
 - Reliable fixed digital detector
 - Elaborated and reliable stand design
 - The generator uses up-to-date knowledge in the field of voltage stabilization and protection against voltage fluctuations and power surges

Basic configurations*

- High voltage generator (HVG)**
 - from **50 kW**; from **65 kW**
- Flat panel detector for fluoroscopy**
 - Digital I.I.
 - Dynamic flat panel detector
- Flat panel detector for radiography**
 - Film cassettes, CR-cassettes with cassette digitizer
 - Flat panel detector for radiography
 - Dynamic flat panel detector
- Vertical stand**
 - Vertical bucky stand or
 - Vertical stand with fixed flat panel detector
- Automated workstations (AWS)**
 - Operator's workstation for system control (radiology technician's AWS)
 - Workstation for the work with examination findings (radiologist's AWS)
 - **Additionally:** medical monitors, medical printer, clinician's workstations, operator's workstations, PACS server
- Specialized software (SW) for radiology technicians and radiologists**
 - Operating the patient and image databases
 - Special APR programs including those for pediatrics
 - Multimodality
 - Support of DICOM 3.0 standard
 - Image postprocessing
 - X-ray dosimetry
 - Color X-ray technology
- X-ray radiation protective equipment for patients and staff**
 - X-ray protective clothes for the medical staff
 - Personal protective equipment for patients
 - X-ray protective windows of different sizes

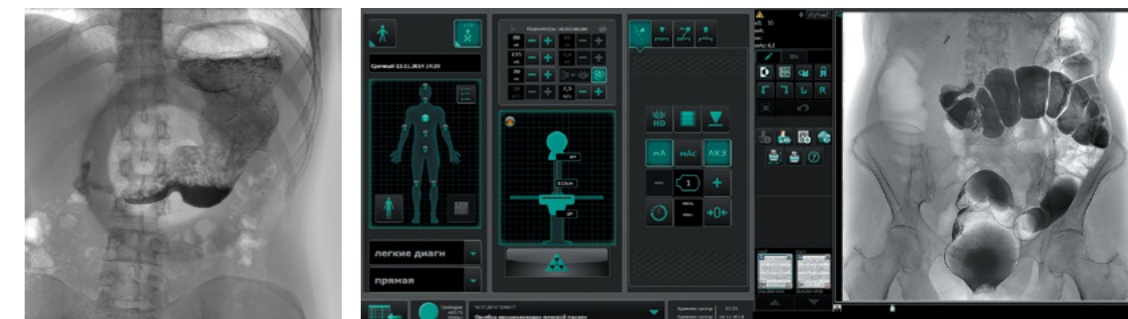

* The "Basic configurations" section includes the information only on the most demanded configurations; the general list is significantly wider. Any configuration and technical parameters can be changed by the manufacturer's initiative or at the customer's request.



VERSATILE X-RAY DIAGNOSTIC SYSTEMS OF EXPERT CLASS



Versatile X-ray diagnostic system meets the highest medical diagnostics requirements. Due to advanced technologies and automation of diagnostics, the highest level of comfort is achieved for both the patient and the staff, the maximum throughput of the room is ensured, and an unlimited range of X-ray examinations is implemented.

The motorized ceiling suspension of the X-ray tube assembly simplifies the access of medical staff to the patient and frees up space for its free positioning. The high level of automation of stand movements allows you to reduce the preparation time for the study and increase the flow of patients with guaranteed diagnostic quality.

The use of both fixed and mobile flat panel detectors in combination with an advanced stand design gives extraordinary flexibility when conducting any X-ray diagnostic studies. It becomes possible to perform examinations on a mobile table and a wheelchair. An expert level of diagnosis of diseases and injuries of the musculoskeletal system is provided, including spine, skull, limbs and other anatomical areas.

The design of the system provides the possibility of full remote control of all functions of the device and its digital system from the control room, also provides maximum radiation protection of medical staff.

The system can be equipped with a remote-controlled table for fluoroscopy. This configuration of the device allows you to perform the entire range of studies that are in demand in modern radiology, including fluoroscopy, radiography and linear tomography. The system also provides diagnostics in the tomosynthesis mode, dual energy, and has possibility for automatic stitching of images to obtain a panoramic image.

State-of-the-art digital imaging system with unique processing algorithms ensures consistently high image quality of any anatomical region in any examination mode. The exposure dose is minimal due to the high sensitivity of flat panel detectors and the use of automatic exposure control technology. That makes the system one of the safest solutions in the field of X-ray diagnostics.

If necessary, the technical solutions used in the system allow establishing a remote connection online to diagnose and remove faults as well as setting up the system to meet the user's demands.

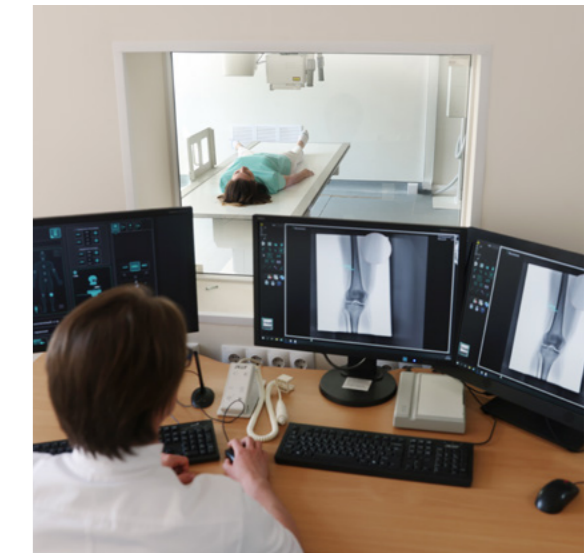

Benefits

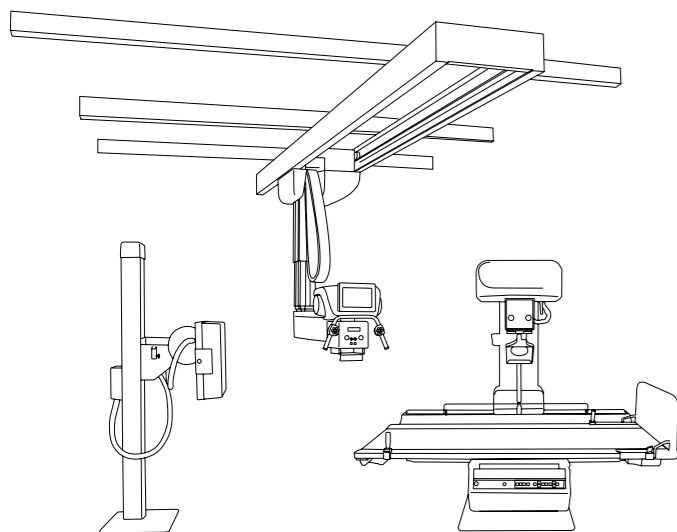

Mobility and multifunctionality

- Motorized ceiling suspension of the X-ray tube provides free access to the patient
- Automated stand movement
- The ability to make images on a stationary patient table, on a mobile table, on a wheelchair
- Any imaging modes - fluoroscopy, radiography, linear tomography, tomosynthesis, double energy, stitching

High diagnostic image quality

- State-of-the-art digital imaging system
- Automated program filters for automatic image processing
- High spatial resolution and speed of fluoroscopy
- Maximum possible size of the detector active area
- State-of-the-art analysis of examination findings

Easiness, simplicity, and user-friendliness

- Fully remote control of all system functions and digital system from the control room
- Ergonomic control system
- X-ray tube assembly automatic positioning

Safety and low exposure dose

- Highly sensitive X-ray detector
- Possibility to perform X-ray examination without a grid
- Wide APR program range for patients of various age and body build
- Automatic exposure control (AEC)
- Possibility to perform fluoroscopy examinations not exposing the staff to radiation

Reliability and durability

- Two reliable fixed digital detectors
- Elaborated and reliable stand design
- The generator uses up-to-date knowledge in the field of voltage stabilization and protection against power surges

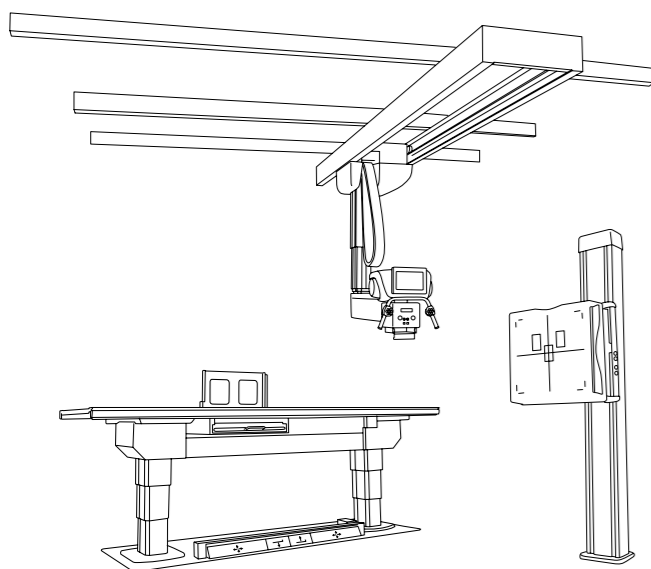

Basic configurations*

High voltage generator (HVG)

Flat panel detector for fluoroscopy and radiography

Fixed patient table

Mobile patient table

Specialized appliances for patient positioning

Automated workstation (AWS)

Specialized software (SW) for radiology technicians and radiologists

X-ray radiation protective equipment for patients and staff

- from **50 kW**; from **65 kW**
- Dynamic flat panel detector
- Fixed flat panel detector
- Mobile flat panel detector
- Bucky table
- Mobile patient table with elevated and floating tabletop
- Light mobile patient table
- Mobile table with floating table top
- Removable footrest
- Shoulder-rests
- Compression belt
- Removable handles for the patient
- X-ray transparent step
- Positioning systems of children of various age groups
- Stand for stitching (obtaining panoramic images)
- Operator's workstation for system control (radiology technician's AWS)
- Workstation for the work with examination findings (radiologist's AWS)
- **Additionally:** medical monitors, medical printer, clinician's workstations, operator's workstations, PACS server
- Operating the patient and image databases
- Specialized APR programs including those for pediatrics
- Multimodality
- Support of DICOM 3.0 standard
- Image postprocessing
- X-ray dosimetry
- Color X-ray technology
- X-ray protective clothes for the medical staff
- Personal protective equipment for patients
- X-ray protective windows of different sizes

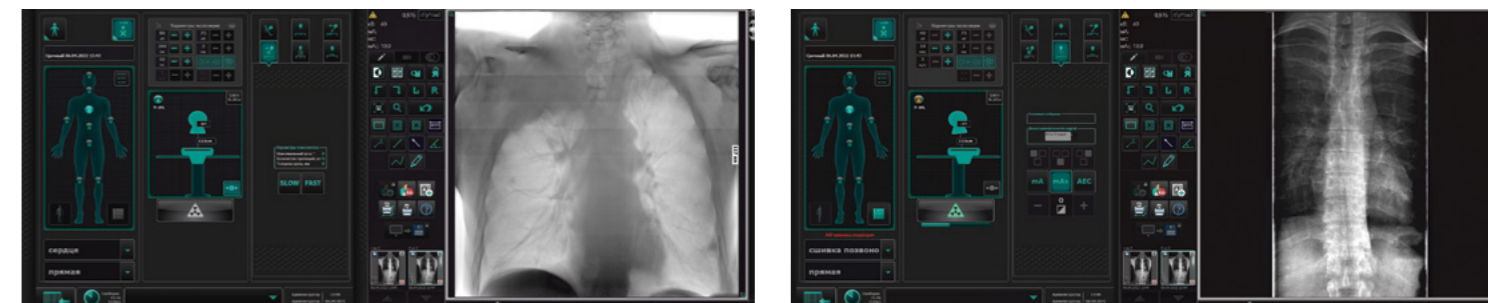

* The "Basic configurations" section includes the information only on the most demanded configurations; the general list is significantly wider. Any configuration and technical parameters can be changed by the manufacturer's initiative or at the customer's request.



DIGITAL RADIOGRAPHY/FLUOROSCOPY SYSTEMS

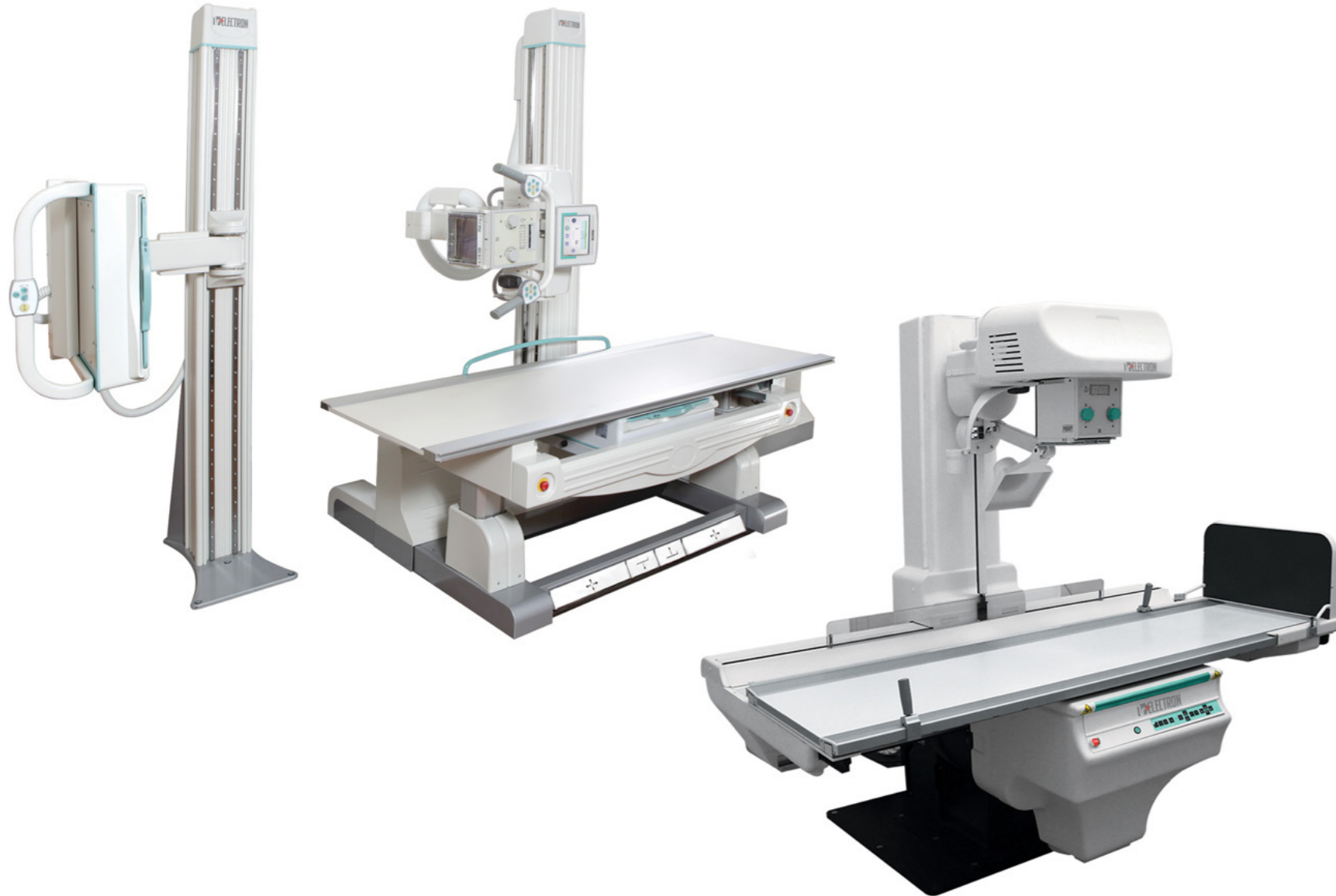

The range of digital radiography/fluoroscopy systems produced by NIPK Electron Co. is a versatile solution allowing to perform the whole examination range in radiography, linear tomography, and fluoroscopy modes, which is relevant in modern radiology.

A specific feature of the system developed by the company is that the system includes a fluoroscopy tilting table with remote control and so all examinations can be performed from the control room. This ensures the operator's comfort and safety.

A modern digital imaging system provides for high image quality. A table for images and a vertical stand are fitted out with large format detectors. It provides for the comfortable performance of any examinations including that of large anatomical regions. Besides, the image has high spatial resolution with the minimum exposure dose for the patient. The high resolution ensures imaging of even minor details in the image, which is a quality guarantee of diagnostics performed.

The stand design has been developed with the maximum possible consideration of the requirements of Russian radiologists. The availability of an elevating tabletop allows regulating its position as required. This facilitates patient positioning to ensure comfort for elderly and injured patients, people with disabilities, and younger children.

The wide range of stand movements provides the possibility to implement even the most complex views and nonstandard positions. The system is fitted out with two ergonomic panels: for remote control of the fluoroscopy tilting table and for direct control at the table. All these features make the system manufactured by NIPK Electron Co. the most convenient digital radiography/fluoroscopy system for the medical staff and patients.

If necessary, the technical solutions used in the system allow establishing a remote connection online to diagnose and remove faults as well as setting up the system to meet the user's demands.

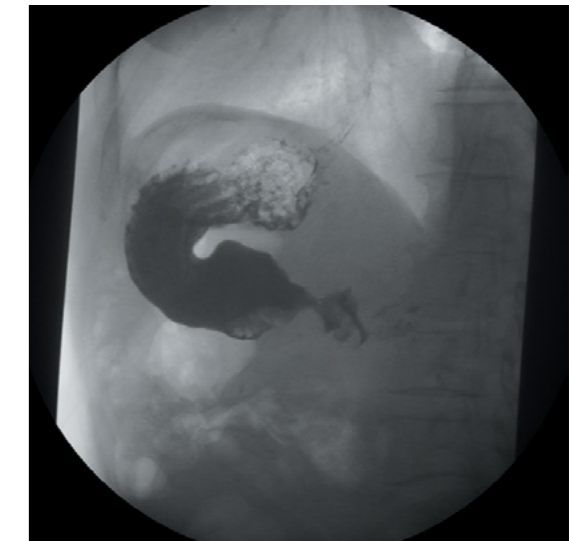

Benefits

Basic configurations*

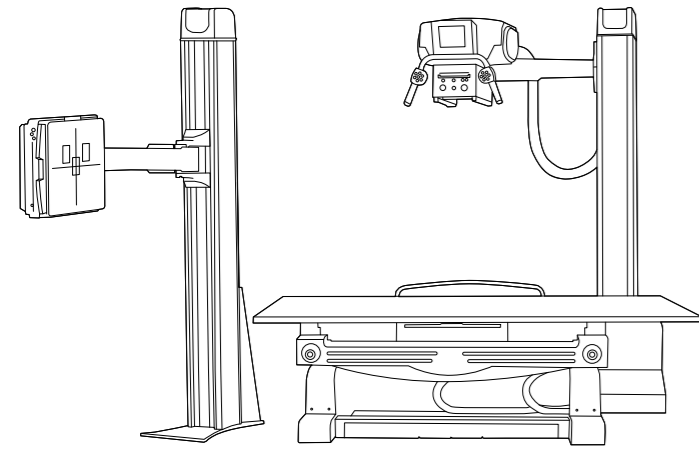

Easiness, simplicity, and user-friendliness

- Possibility to control movements of a fluoroscopy tilting table
- remotely
- Possibility of control directly beside the fluoroscopy tilting table
- Motorized movement of stands, a detector, an X-ray source, and a tabletop
- User-friendly ergonomic remote control console
- Color touch display
- Multilingual interface

High diagnostic image quality

- State-of-the-art digital imaging system
- Automated program filters for image processing
- High spatial resolution
- Maximum possible size of the detector active area
- State-of-the-art analysis of examination findings
- High fluoroscopy rate

Mobility and multifunctionality

- The widest range of system movement
- Wide range of tomography angle setting
- Diagnostic imaging of the extremities with the examined region positioned directly on the detector surface
- Examinations in oblique, axial, and tangential views

Safety and low exposure dose

- Highly sensitive digital X-ray detectors
- Removable grid
- Wide APR program range for patients of various ages and body build
- Automatic exposure control (AEC)
- Possibility to perform all examination types, including fluoroscopy, from the control room

Reliability and durability

- Reliable fixed digital detectors
- Elaborated and reliable stand design
- The generator uses up-to-date knowledge in the field of voltage stabilization and protection against voltage fluctuations and power surges

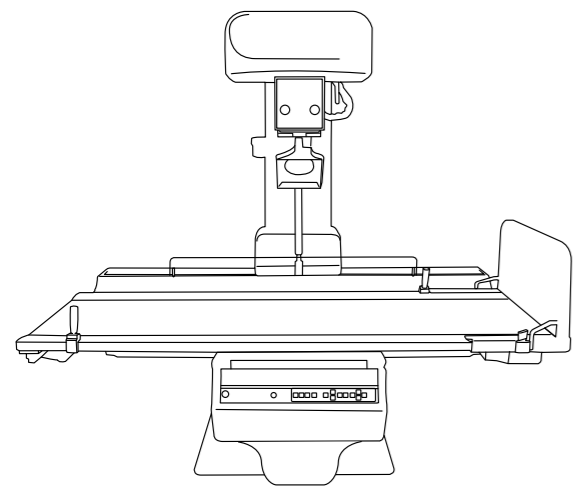

High voltage generator (HVG)

- from **50 kW**; from **65 kW**

Flat panel detector for fluoroscopy

- Digital I.I.

Flat panel detector for radiography

- Flat panel detector

Vertical stand

- Elevating tabletop
- Motorized movement of stands, a detector, an X-ray source and tabletop
- The stand with the possibility to move a detector beneath a mobile patient table and for imaging the extremities directly on the detector
- X-ray tube assembly with motorized movement providing for focal distance maintenance and automatic
- X-ray tube assembly positioning onto a detector of a vertical stand

Automated workstations (AWS)

- Operator's workstation for system control (radiology technician's AWS)
- Workstation for the work with examination findings (radiologist's AWS)
- **Additionally:** medical monitors, medical printer, clinician's workstations, operator's workstations, PACS server

Specialized software (SW) for radiology technicians and radiologists

- Operating the patient and image databases
- Special APR programs including those for pediatrics
- Multimodality
- Support of DICOM 3.0 standard
- Image postprocessing
- X-ray dosimetry
- Color X-ray technology

Specialized appliances for patient positioning

- X-ray transparent step
- Positioning systems of children of various age groups

X-ray radiation protective equipment for patients and staff

- X-ray protective clothes for the medical staff
- Personal protective equipment for patients
- X-ray protective windows of different sizes





DIGITAL RADIOGRAPHY SYSTEMS

Radiography systems produced by NIPK Electron Co. are modern, fully digital and equipped with the linear tomography function. Being developed taking into account the actual needs of the medical community, our systems are available today in many healthcare facilities of the country and proved themselves to be excellent for performing routine radiography examinations.

A unique control system provides for the easiness and rate of the examination: the availability of an elevating tabletop allows regulating its height in the wide range. This facilitates patient positioning, which is very comfortable for elderly and injured patients, people with disabilities, and younger children. The wide range of stand movements provides the possibility to implement even the most complex views and nonstandard positions. The software allows setting the exposure parameters automatically.

An imaging system based on a flat panel detector, specialized program filters, APR programs, which consider the patient's age and body build, allow obtaining a high-quality image with minimum exposure dose.

The digital radiography systems can feature both the right-sided and the left-sided position of the vertical stand. This allows arranging the ergonomic working space.

While combining the advanced digital technologies and maximum of functional possibilities, our systems provide for the high diagnostic quality and effective work of the X-ray room.

If necessary, technical solutions used in the system allow implementing the remote connection in the online mode to diagnose and remove faults and also set up the system to meet the user's demands.



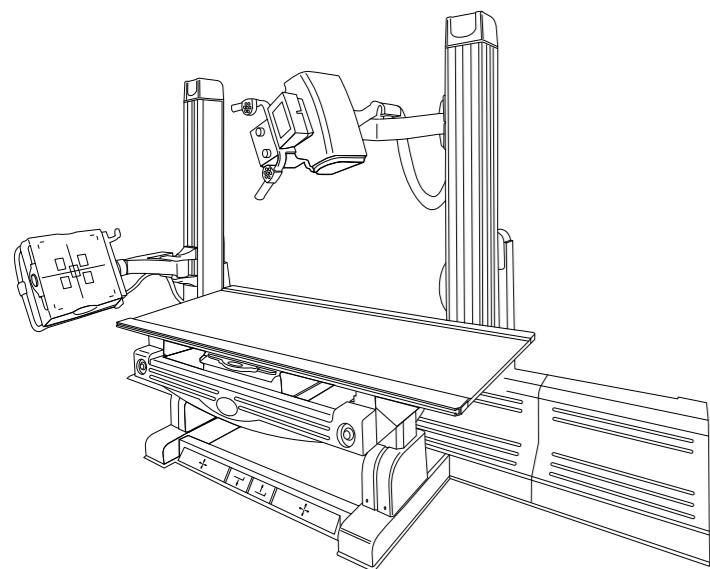

Benefits

- High diagnostic image quality**
 - State-of-the-art digital imaging system
 - Automated program filters for image processing
 - High spatial resolution
 - Maximum possible size of the detector active area
 - State-of-the-art analysis of examination findings
- Easiness, simplicity, and user-friendliness**
 - Motorized movement of the tube stand and the tabletop
 - Ergonomic control consoles in the control room and on the X-ray tube assembly
- Safety and low exposure dose**
 - Highly sensitive digital detectors
 - Removable grid
 - Wide APR program range for patients of various ages and body build
 - Automatic exposure control (AEC)
- Multifunctionality**
 - Wide range of tomography angle setting
 - The widest range of system movement
 - Diagnostics of the extremities with the examined region positioned directly on the detector surface
 - Examinations in oblique, axial, and tangential views
 - Possibility of imaging in the lateral position
- Reliability and durability**
 - Two reliable fixed digital detectors
 - Elaborated and reliable stand design
 - The generator uses up-to-date knowledge in the field of voltage stabilization and protection against voltage fluctuations and power surges

Basic configurations*

- High voltage generator (HVG)**
 - from **50 kW**; from **70 kW**
- Digital detectors**
 - Flat panel detector
- Stand**
 - Elevating tabletop
 - The vertical stand with the possibility to turn a detector with its operating field upwards for imaging the extremities directly on the detector
 - Motorized movement of the tube stand and the tabletop
- Automated workstations (AWS)**
 - Operator's workstation for system control (radiology technician's AWS)
 - Workstation for the work with examination findings (radiologist's AWS)
 - **Additionally:** medical monitors, medical printer, clinician's workstations, operator's workstations, PACS server
- Specialized software (SW) for radiology technicians and radiologists**
 - Operating the patient and image databases
 - Special APR programs including those for pediatrics
 - Multimodality
 - Support of DICOM 3.0 standard
 - Image postprocessing
 - X-ray dosimetry
 - Color X-ray technology
- Specialized appliances for patient positioning**
 - X-ray transparent step
 - Positioning systems of children of various age groups
- X-ray radiation protective equipment for patients and staff**
 - X-ray protective clothes for the medical staff
 - Personal protective equipment for patients
 - X-ray protective windows of different sizes



DIGITAL RADIOGRAPHY SYSTEMS WITH A MOBILE TABLE

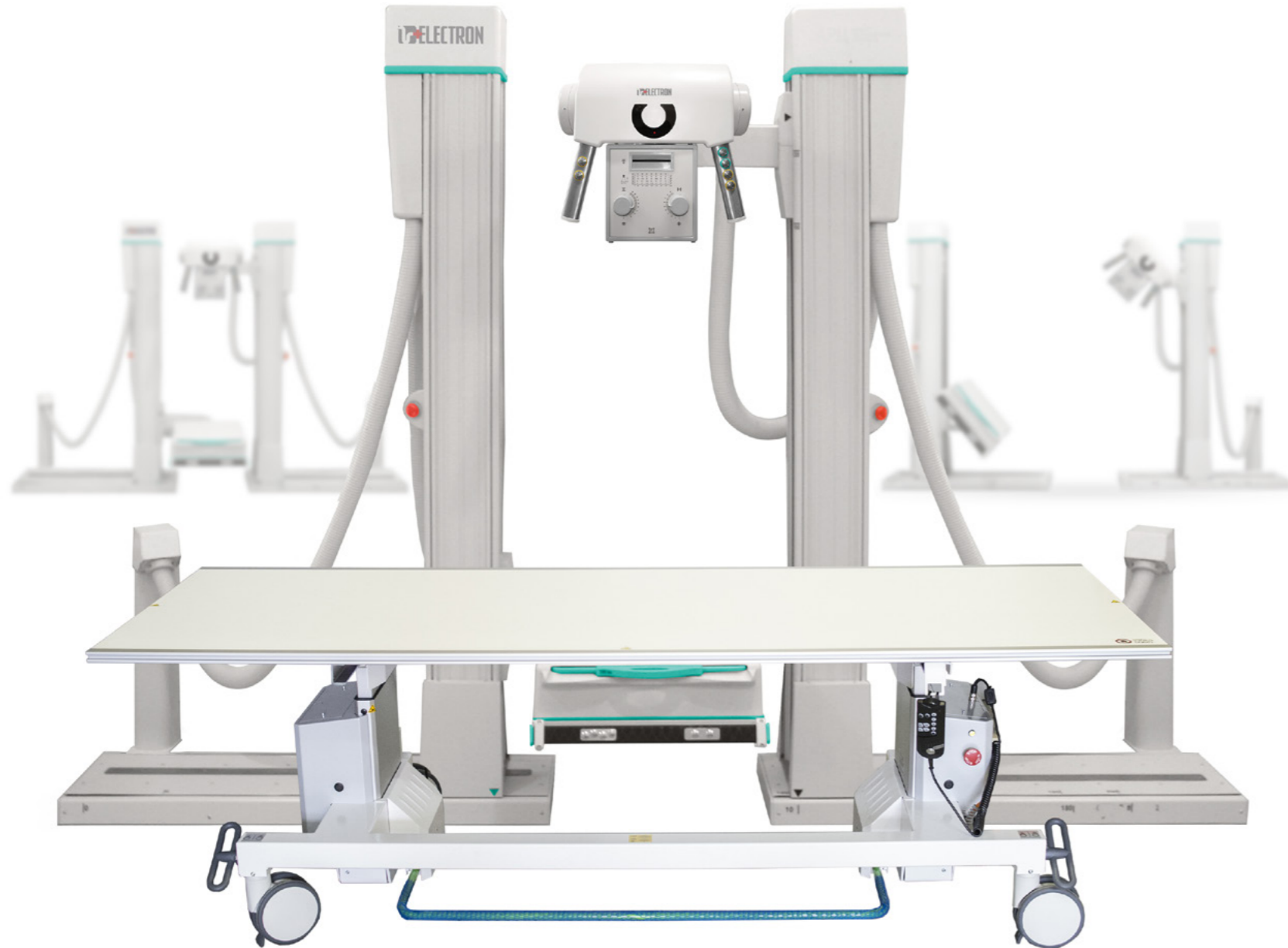

A rational solution for routine radiography combines easiness to operate the systems, ergonomic design and reliability even during intensive use, high diagnostic image quality.

The unique design of digital radiography systems with a mobile table makes it possible to perform examinations without unnecessary movements of the patient implementing even the most complex views/positions. The detector and the X-ray tube assembly move freely around the patient, allowing them to stay in a comfortable position, which is particularly important for nonmobile and injured patients. The systems are fitted out with a mobile patient table, which can be used as a trolley for patient transportation. All these features significantly facilitate the work of a radiology technician, lowers the staff exertion, saves time for performing an examination, and increases the X-ray room throughput.

A maximally easy and comfortable control system allows mastering the skills for operating the system in the shortest possible time. A specially designed X-ray positioning guide app helps a technician make a scan correctly: when the examined anatomical region and a view are selected, the program suggests a prompt, i.e., the picture illustrating the optimum way to position the patient.

An imaging system based on a flat panel detector, specialized program filters, APR programs, which consider the patient's age and body build, allow obtaining a high-quality image with minimum exposure dose.

Digital radiography systems with a mobile table occupy a small area and can have both the right-sided and the left-sided position of the tube stand. This allows arranging the working space effectively.

If necessary, the technical solutions used in the systems allow establishing a remote connection online to diagnose and remove faults as well as setting up the system to meet the user's demands.



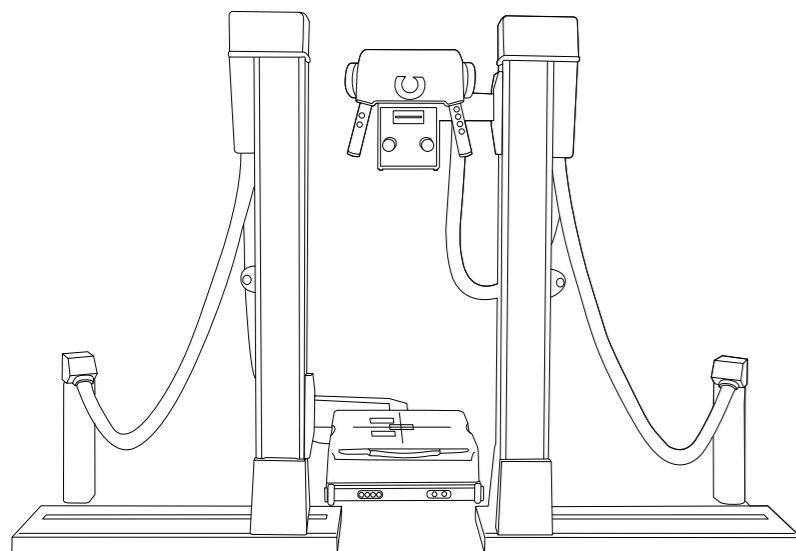

Benefits

- Mobility and multifunctionality**
 - Possibility to realize all required patient's views/positions (in the upright, the sitting, and the supine position)
 - Free movement of a detector and X-ray tube assembly around a patient
 - Mobile patient table
 - Implementation of complex views/positions
 - Performing examination of the extremities directly on the detector surface, without the need to position the patient on the table
 - Performing examinations in a lateral position on a mobile patient table
- Easiness, simplicity, and user-friendliness**
 - Ergonomic control system
 - Built-in electronic X-ray positioning guide app
 - Multilingual interface
 - Motorized stand movements
 - Small dimensions and the minimum occupied area
 - The left-side or the right-side position of the tube stand
 - Rapid and easy preparation for an examination
 - High X-ray room throughput
- High diagnostic image quality**
 - State-of-the-art digital imaging system
 - Automated program filters for image processing
 - High spatial resolution
 - Maximum possible size of the detector active area
 - State-of-the-art analysis of examination findings
- Safety and low exposure dose**
 - Highly sensitive X-ray detector
 - APR programs for patients of different ages and body-build
 - Automatic exposure control (AEC)
 - Special collision protection sensors
- Reliability and durability**
 - Simple system design to minimize the probability of damages
 - Simple and reliable controls
 - The generator uses up-to-date knowledge in the field of voltage stabilization and protection against voltage fluctuations and power surges

Basic configurations*

- High voltage generator (HVG)**
 - from **30 kW**; from **50 kW**; from **70 kW**
- Digital detectors**
 - Flat panel detector
- Automated workstations (AWS)**
 - Unified technician' and radiologist's AWS (a workstation combining the system control functions and functions of work with examination findings)
 - or
 - Operator's workstation for system control (radiology technician's AWS)
 - Workstation for the work with examination findings (radiologist's AWS)
 - **Additionally:** medical monitors, medical printer, clinician's workstations, operator's workstations, PACS server
- Specialized software (SW) for radiology technicians and radiologists**
 - Operating the patient and image databases
 - Special APR programs including those for pediatrics
 - Multimodality
 - Support of DICOM 3.0 standard
 - Image postprocessing
 - X-ray dosimetry
 - Color X-ray technology
- Mobile patient tables**
 - Light mobile patient table
 - Mobile patient table with elevated and floating tabletop
- Specialized appliances for patient positioning**
 - X-ray transparent step
 - Positioning systems of children of various age groups
- Assembling the system taking into account peculiarities of the room**
 - Assembling the stand both on the right and the left side
 - The base rail can be assembled at the floor level or higher depending on peculiarities of the room
- X-ray radiation protective equipment for patients and staff**
 - X-ray protective clothes for the medical staff
 - Personal protective equipment for patients
 - X-ray protective windows of different sizes



CHEST X-RAY SYSTEMS

The chest X-ray systems produced by NIPK Electron Co. are well-known to Russian radiologists – chest X-ray systems for examinations of the thoracic organs are installed and operated in most Russian clinics.

Taking into consideration many years of experience of interaction with tuberculosis specialists and oncologists and understanding relevant radiologists' professional needs, the Company continuously develops advanced equipment models. Chest X-ray systems are fitted out with state-of-the-art flat panel detectors, which allow obtaining an image with maximum spatial resolution.

The examinations using open-type chest X-ray systems can be performed in the upright and the sitting position, which is especially relevant for elderly and injured patients. The large detector area allows performing full examination within one exposure irrespective of the chest size. A stand with motorized arm movement and X-ray protective equipment fixed on it facilitates significantly the work of a radiology technician, lowers the staff exertion, and saves time for an examination.

Open-type chest X-ray double-stand systems make it possible to perform an examination of the patients in both the upright and the sitting position due to free movement of a detector and X-ray tube assembly along the body. There is also an option to perform an examination when the patient lies in the lateral position on a mobile patient table.

Cabin chest X-ray systems are fitted out with a motorized elevating stand for the patient and provide for the maximum X-ray protection of the medical staff due to the design of the stand.

Chest X-ray systems of the range manufactured by NIPK Electron Co. ensure the superior diagnostic image quality with the minimum exposure dose, provide the possibility not only to divide the patient flows to the "normal" and "abnormal" findings but also to perform differential diagnosis and make a preliminary diagnosis as early as possible.

The basic specifications of digital chest X-ray systems provide for the increased X-ray room throughput with preserving permanently high diagnostic quality. All these features help start the treatment in due time, save lives and preserve the patient health.

If necessary, the technical solutions used in the range of chest X-ray systems allow establishing a remote connection online to diagnose and remove faults as well as setting up the system to meet the user's demands.

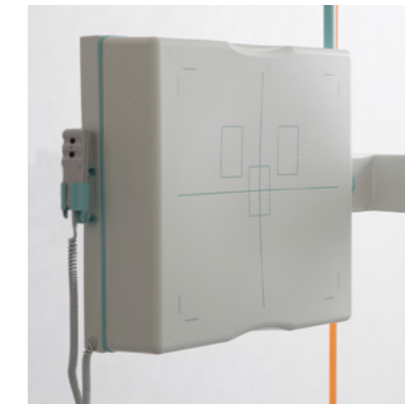
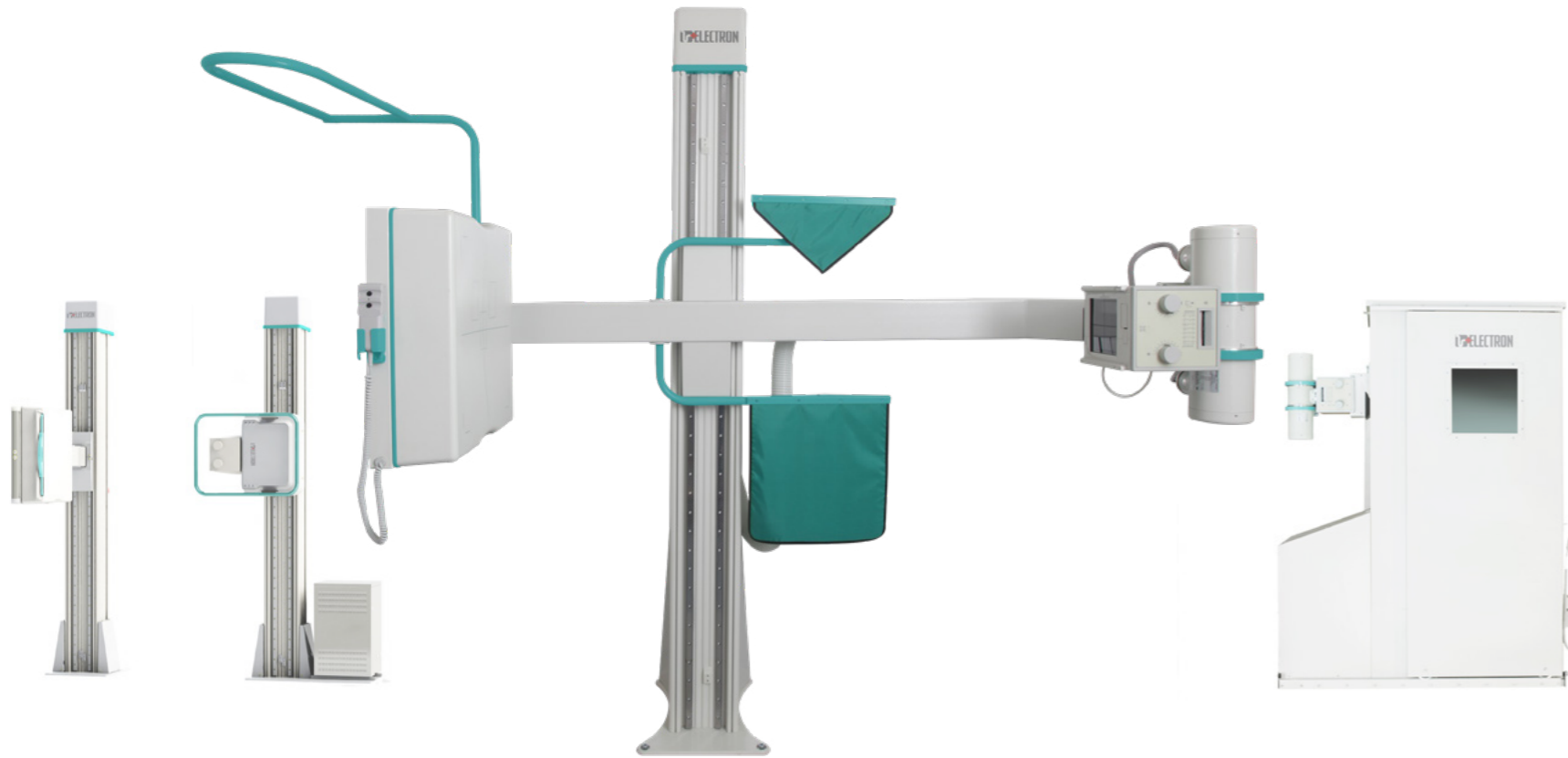

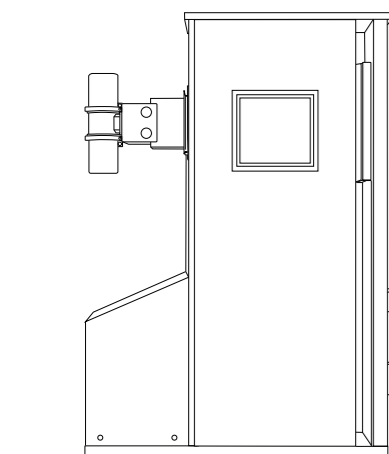
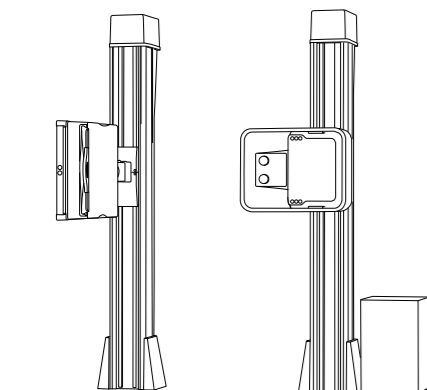
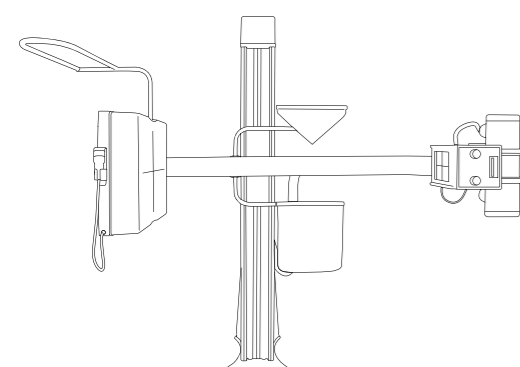

High diagnostic quality of the image

- Large focal distance
- Maximum possible size of detector area
- High spatial resolution
- State-of-the-art digital imaging system
- Specialized automated program filters for image processing
- State-of-the-art analysis of examination findings

Easiness, simplicity, and user-friendliness

- The possibility to see the patient and adjust their position due to the stand's open design or the built-in video camera
- Motorized vertical movement of a detector and X-ray tube assembly or the patient elevating stand
- Multilingual interface

Safety and low exposure dose

- Gonads and thyroid X-ray protection
- Minimum exposure time
- Modern highly sensitive detector
- Wide APR program range

Reliability and durability

- A simple and reliable system design with the maximum throughput
- The generator uses up-to-date knowledge in the field of voltage stabilization and protection against voltage fluctuations and power surges

Unique benefits

- Open-type chest X-ray single-stand systems:**
- Possibility to perform an examination of the patients in both the upright and the sitting position due to free movement of the detector and the X-ray tube assembly along the body
 - Patient X-ray protective equipment fixed on the arm
 - A removable handle for convenient for lateral view examinations

- Cabin chest X-ray system:**
- Maximum X-ray protection of the medical staff
 - Small size

- Chest X-ray double stand systems:**
- Comfortable patient positioning and performing an examination in the upright and the sitting position
 - An option to perform an examination when the patient lies in the lateral position on a mobile patient table
 - Easy patient approach to the system

Benefits

Basic configurations*

High voltage generator (HVG)

- from **30 kW**; from **40 kW**; from **50 kW**; from **65 kW**

Digital detectors

- Flat panel detector

Stands and focal distance

Open-type:

- up to 120 cm
- up to 150 cm
- up to 180 cm

Closed-type:

- up to 120 cm

Automated workstations (AWS)

- Operator's workstation for system control (radiology technician's AWS)
- Workstation for the work with examination findings (radiologist's AWS)
- **Additionally:** medical monitors, medical printer, clinician's workstations, operator's workstations, PACS server

Specialized software (SW) for radiology technicians and radiologists

- Operating the patient and image databases
- Specialized APR programs including those for pediatrics
- Multimodality
- Support of DICOM 3.0 standard
- Image postprocessing
- X-ray dosimetry
- Color X-ray technology

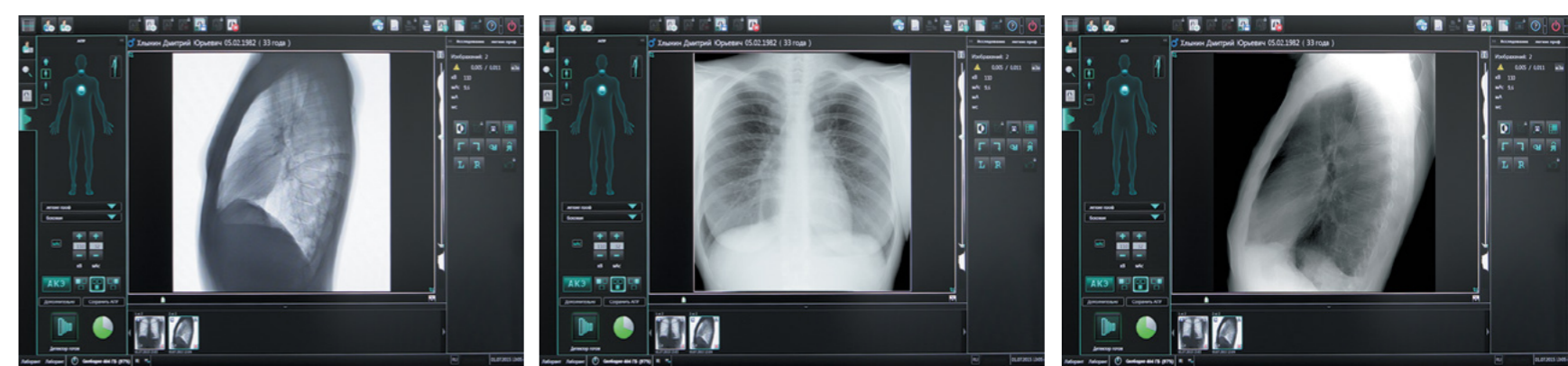

* The "Basic configurations" section includes the information only on the most demanded configurations; the general list is significantly wider. Any configuration and technical parameters can be changed by the manufacturer's initiative or at the customer's request.



MOBILE RADIOGRAPHY SYSTEMS



The range of mobile radiography systems manufactured by NIPK Electron Co. combines the high image quality, small size, easiness of movement, and mobility. The systems are designed to perform a wide range of examinations at intensive care units, departments of traumatology, emergency rooms, admission, and hospital wards to perform diagnostic imaging in patients that cannot be moved. Both digital and film radiography options may be available depending on the modification.

A digital system with a wired or Wi-Fi flat panel detector and built-in operator's automated workstation is the most comfortable and modern solution today; these components allow obtaining and transferring high quality images rapidly irrespective of the examination location. A wide dynamic range, high DQE and contrast sensitivity of detector provide for imaging of both bone structures and soft tissues. The image quality achieved using mobile radiography systems is the same as that of the images made using modern high-class fixed systems.

A lightweight, mobile, and well-balanced stand allows moving the system without any efforts, ensures positioning convenience and accuracy. A wide range of X-ray tube assembly rotations allows performing imaging in oblique views.

The possibility to move forward support with an X-ray tube assembly for more than 100 cm relative to a stand helps to perform examinations of any regions in a bedridden patient.

A built-in operator's automated workstation provides for comfortable system control using a touch display, which is protected from accidental pressing. The wide software resources and a user-friendly multilingual interface allow simplifying and facilitating the work of the radiology technician to the maximum extent.

Mobile radiography systems on a motorized stand with built-in rechargeable batteries make it possible to move the system without any efforts and perform imaging without connecting it to the power grid. The system features a small-sized body and has the minimum weight and overall dimensions among all systems of this class available on the Russian market.

If necessary, technical solutions used in the mobile radiography systems produced by NIPK Electron Co. allow implementing the remote connection in the online mode to diagnose, removing faults, and setting up the system to meet the user's demands.



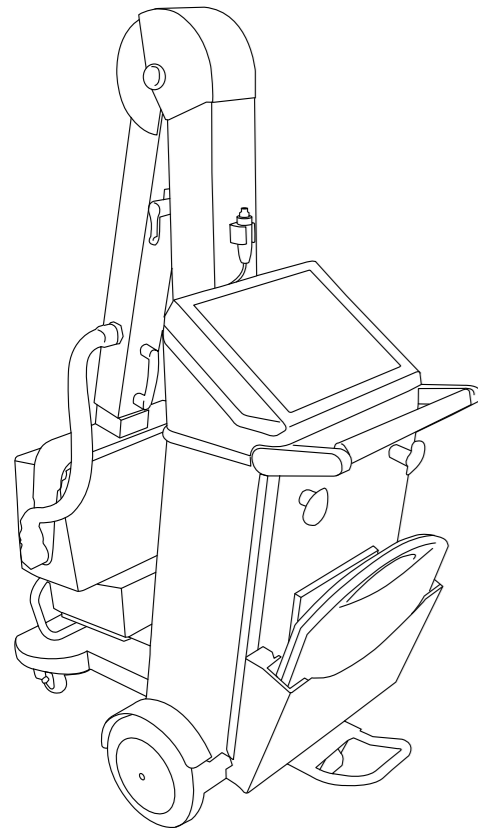

Benefits

- High diagnostic image quality**
 - State-of-the-art digital imaging system
 - Automated program filters for automatic image processing
 - High spatial resolution
 - State-of-the-art analysis of examination findings
- Easiness, simplicity, and user-friendliness**
 - Built-in operator's automated workstation
 - Color touch display
 - Multilingual interface
 - Image view and processing option using the built-in operator's automated workstation
 - Built-in dose meter for absorbed dose check
 - Disk recording and examination result archiving option
 - Sending images to the PACS
- Mobility and multifunctionality**
 - Lightweight, mobile, and well-balanced stand including a motorized stand
 - Footboard for passing door sills and low steps
 - A wide range of X-ray tube assembly rotations
 - Possibility to move forward support with an X-ray tube assembly for more than 100 cm relative to the stand
 - Equipping with a mobile vertical stand is possible
- Safety and low exposure dose**
 - Highly sensitive X-ray detector
 - APR programs for patients of different ages and body build
 - Built-in operator's automated workstation display protection against accidental pressing
 - Treatment of a display with disinfecting solutions are allowed
 - Exposure remote switching panel
 - Braking system is unlocked by pressing the system movement handle or the special foot pedal
- Reliability and durability**
 - Elaborated, simple, and reliable system design
 - The newest products in the field of voltage stabilization and protection against power surges

Basic configurations*

- High voltage generator (HVG)**
 - from **4 kW**; from **15 kW**; from **25 kW**; from **40 kW**
- Flat panel detector for radiography**
 - Mobile wired or Wi-Fi flat panel detector
 - CR-cassettes with the cassette digitizer
 - Film cassettes
- Mobile stand**
 - Lightweight stand, without motorization
 - Stand with built-in rechargeable batteries, without motorization
 - Motorized stand with built-in rechargeable batteries
- Automated workstations (AWS) for digital systems**
 - Built-in operator's automated workstation
 - Workstation for the work with examination findings (radiologist's AWS)
 - Additionally:** medical monitors, medical printer, clinician's workstations, operator's workstations, PACS server
- Specialized software (SW) for radiology technicians and radiologists**
 - Operating the patient and image databases
 - Specialized APR programs including those for pediatrics
 - Multimodality
 - Support of DICOM 3.0 standard
 - Image postprocessing
 - X-ray dosimetry
 - Color X-ray technology
- Accessories**
 - Mobile vertical stands
 - X-ray transparent wheel table
- X-ray radiation protective equipment for patients and staff**
 - X-ray protective clothes for the medical staff
 - Personal protective equipment for patients



* The "Basic configurations" section includes the information only on the most demanded configurations; the general list is significantly wider. Any configuration and technical parameters can be changed by the manufacturer's initiative or at the customer's request.



FILM-SCREEN RADIOGRAPHY/ FLUOROSCOPY SYSTEMS

The Company produces a range of conventional film-screen radiography/fluoroscopy systems for those who prefer to work with film images.

For many years the film-screen radiography/fluoroscopy systems produced by NIPK Electron Co. have been distinguished by high reliability and operation stability. They have become highly appreciated by Russian radiologists over many years of operation and are still in demand today.

These systems allow performing the entire range of X-ray examinations: radiography, pulsed fluoroscopy, linear tomography, and can be used successfully both at outpatient clinics and hospitals of different specialties.

Elaborated classical design determines their usability. The tabletop height variation option makes it easier to perform examinations of children, elderly people, patients with restricted mobility, or injured patients. A floating tabletop provides for rapid and accurate patient positioning.

The system design makes it possible to perform an examination of the patients on a mobile patient table or in a wheelchair. The system can have both right-sided and left-sided position of a vertical stand, what helps to arrange effectively the working space.

The range of configurations of analogue units for two and three workstations allows passing smoothly to digital technologies.

The system can be fitted out with a vertical stand with a fixed detector, digitizing system, or portable flat panel detector. The system can include a vertical stand with a fixed flat panel detector for those who need frequent chest examinations in digital format.

Being fitted out with a digitizer, film-screen radiography/fluoroscopy systems allow obtaining a digital image with CR-cassettes, which can be used in the bucky. Professionals obtain digital images after digitalization of these cassettes using a special system.

A radiography/fluoroscopy system fitted out with a portable flat panel detector provides for radiography examinations in the digital format, due to which the medical staff gets all benefits of working with a digital image. These include immediate imaging, considerably lower exposure dose, and significantly larger diagnostic information amount as compared to a film image: one image can show both soft and dense tissues. The system can be fitted out with a fluoroscopy tilting table at healthcare facilities where fluoroscopy is required.

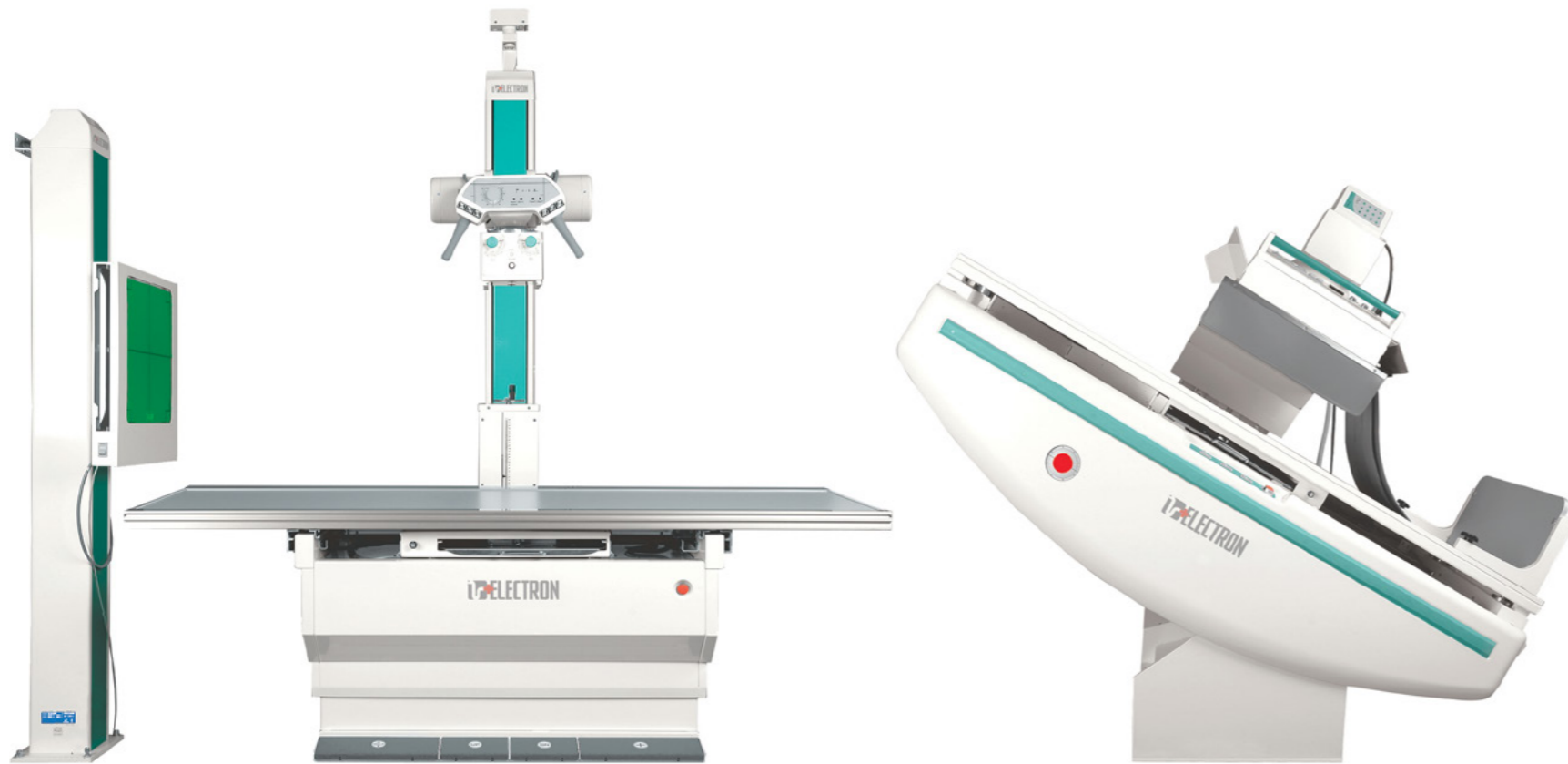

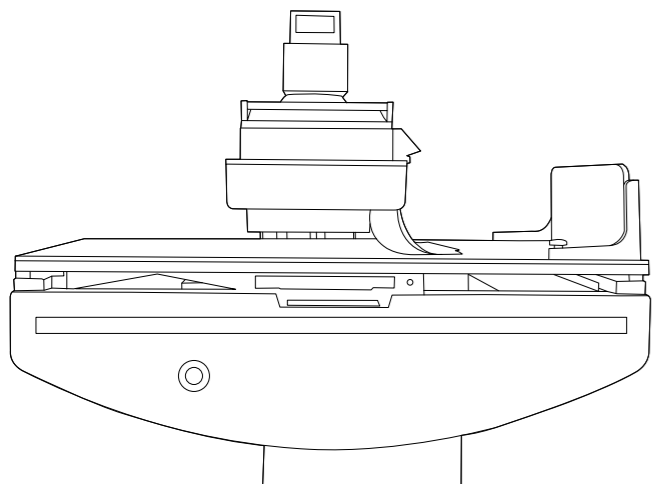
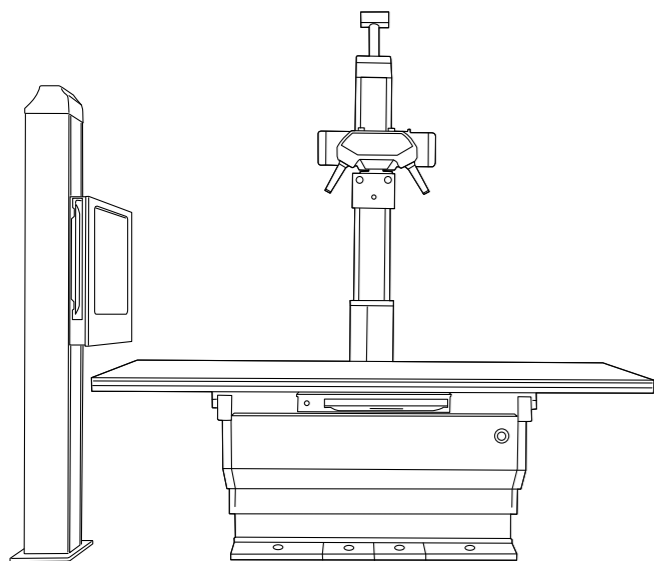

Benefits

- High diagnostic quality of the image**
 - Time-proved quality of film-screen radiography
 - Configuration option with a digital detector with high spatial resolution
- Mobility and multifunctionality**
 - Elevating tabletop to facilitate patient positioning
 - Floating tabletop
 - Possibility to move the X-ray tube assembly in the transverse direction for performing examinations of any anatomical region without additional movement of the patient
- Reliability and durability**
 - Reliable, elaborated classical design
 - The latest R&D products in the field of voltage stabilization and protection against power surges
- Easiness, simplicity, and user-friendliness**
 - User-friendly HVG control console
 - Multilingual interface
 - Built-in dose meter for absorbed dose check
- Safety and low exposure dose**
 - Wide APR program range for patients of various ages and body build
 - Automatic exposure control (AEC)

Basic configurations*

- High voltage generator (HVG)**
 - from **50 kW**; from **65 kW**
- Workstations**
 - Fluoroscopy tilting table
 - Bucky table
 - Vertical stand for images with the cassette bay
 - Vertical stand for images with the fixed digital detector
- Flat panel detector for fluoroscopy**
 - Digital I.I.
- Flat panel detector for radiography**
 - Film cassettes
 - CR-cassettes with the cassette digitizer
 - Portable Wi-Fi flat panel detector
 - Reliable fixed digital detector
- Automated workstations (AWS) for digital systems**
 - Built-in operator's automated workstation
 - Workstation for the work with examination findings (radiologist's AWS)
 - **Additionally:** medical monitors, medical printer, clinician's workstations, operator's workstations, PACS server
- Auxiliary equipment**
 - Film development machine
 - Digitizer with the operator's workstation
- X-ray radiation protective equipment for patients and staff**
 - X-ray protective clothes for the medical staff
 - Personal protective equipment for patients
 - X-ray protective windows of different sizes

* The "Basic configurations" section includes the information only on the most demanded configurations; the general list is significantly wider. Any configuration and technical parameters can be changed by the manufacturer's initiative or at the customer's request.



X-ray interventions





X-RAY ANGIOGRAPHY SYSTEMS



The X-ray angiography system developed by NIPK Electron Co. is a versatile system, which allows performing a wide range of diagnostic procedures:

- Angiography of the brain and cervical vessels
- Angiography of the abdominal cavity, liver, and kidneys
- Coronarography
- Peripheral angiography
- Microangiography of the extremities vessels

The angiography system allows controlling medical interventions in cardiology, angiology, neurology, oncology, and other fields:

- Endovascular interventions on vessels in all anatomical areas
- Electrophysiology testing and procedures
- Balloon angioplasty, stent positioning, embolization of any vessels
- Cava-filters implantation and thrombolysis
- Drainage and stenting of ducts

A special value of the angiography system consists in high information content of the obtained image. A unique imaging system based on a flat panel detector with spatial resolution of 50 μm , which is superior to foreign analogues regarding its specifications, ensures high diagnostic imaging quality. The examinations allow not only to obtain information about the functional state of the vessels and reveal the signs of disorders but also help determine the accurate localization and seriousness of the revealed abnormality using special calculation packages.

In addition to the set of standard image processing functions, as well as the vessel and cardiac function parameters calculation packages, the system software includes specialized packages, which are necessary for the effective work of endovascular surgeons:

- Digital subtraction angiography (DSA) with choice of subtraction level (Landmark)
- Road Map function for convoluted and difficult to pass parts of a vessel
- Package for real-time visualization of the implantable stent
- Perfusion subtraction angiography for brain perfusion analysis
- Bolus Chasing

Due to a wide range of functions in combination with the affordability of purchasing and ownership of the system, the angiography system is the optimum solution for most healthcare facilities and allows successful coping with cardiovascular diseases, particularly in emergency situations. If necessary, technical solutions used in the system allow implementing the online remote connection to diagnose and remove faults and also set up the system to meet the user's demands.

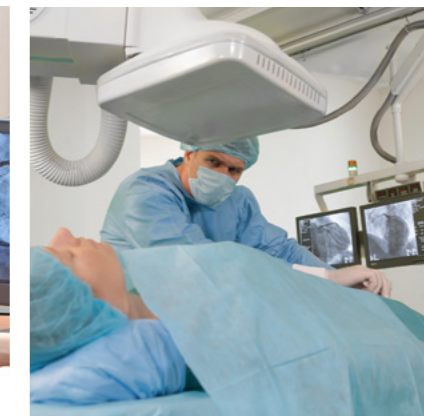

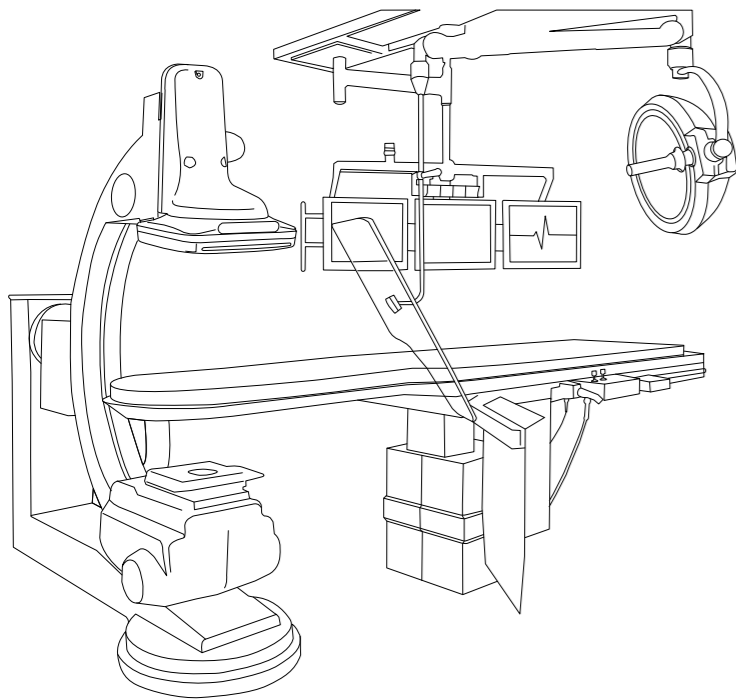

- High image quality**
 - State-of-the-art digital imaging system
 - Sensitive flat panel detector with a spatial resolution of up to 5 lp/mm
 - High-information matrix with the pixel size of 50 µm
 - Specialized program filters for image processing
- User-friendliness**
 - Wide scope of application
 - Data analysis software
 - Specialized packages
 - User-friendly multilingual interface
 - Ergonomic control system
- Safety and low exposure dose**
 - High DQE
 - Specific compensation filters
 - 6 imaging fields
 - Wide APR program range
- Reliability and durability**
 - Efficient forced cooling system
 - Radiologist's and operator's automated workstation interchangeability
 - The generator uses up-to-date knowledge in the field of voltage stabilization and protection against voltage fluctuations and power surges

Benefits

Basic configurations*

- Digital detectors**
 - Cardiological dynamic flat panel
 - Versatile dynamic flat panel
- Specialized software (SW)**
 - Image postprocessing
 - Digital subtraction angiography (DSA)
 - Cardio package
 - Vascular package
 - Road Map
 - Package for real-time visualization of the implantable stent
 - Perfusion subtraction angiography for brain perfusion analysis
 - Bolus Chasing
- Additional equipment**
 - Ceiling mount with displays
 - Automatic injector
 - Cardiac monitor
 - Surgical lamp
 - Medical printer
 - Clinician's workstations
 - Medical monitors
 - PACS server
- X-ray radiation protective equipment for patients and staff**
 - Ceiling suspension X-ray protective shield
 - Ceiling suspension X-ray protective apron
 - X-ray protective clothes for the medical staff
 - Personal protective equipment for patients

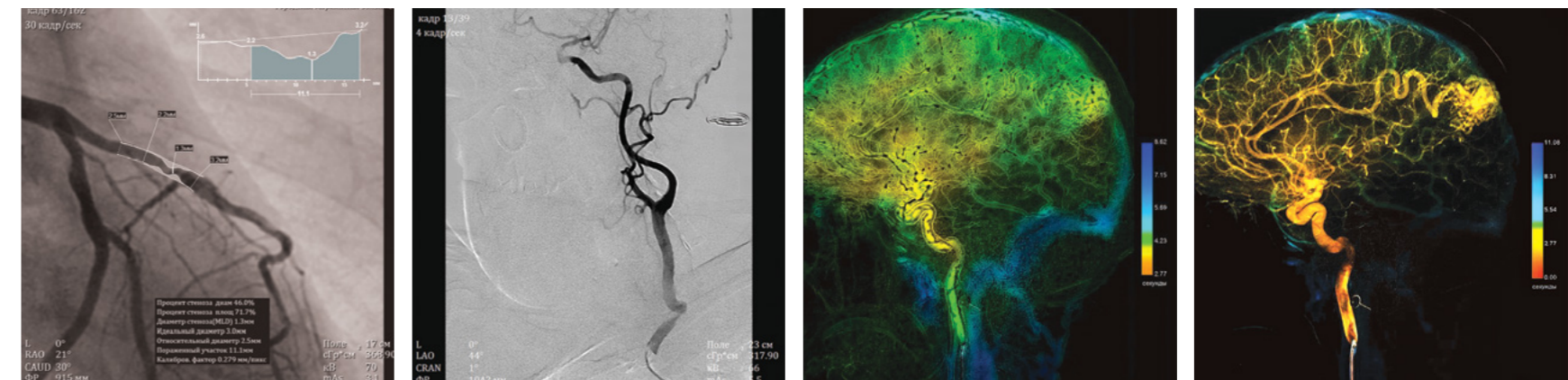

* The "Basic configurations" section includes the information only on the most demanded configurations; the general list is significantly wider. Any configuration and technical parameters can be changed by the manufacturer's initiative or at the customer's request.



MOBILE C-ARM SYSTEMS



The Company's product portfolio includes a wide range of mobile C-arm systems of different power for X-ray guided surgery, minimally invasive surgery and interventions for patients with various disorders, e.g. in orthopedics and traumatology, abdominal surgery, urology and gynecology, vascular surgery, and cardiac surgery practice.

The high image quality provided by mobile C-arm systems is achieved due to a digital imaging system, which allows seeing even the smallest defects and pathologies. A mobile C-arm system model with a flat panel detector provides for imaging of even the smallest vessels. The modes of pulsed fluoroscopy, lowered dose fluoroscopy, and special quality fluoroscopy in combination with the wide APR program range, which considers the patient's age and the body build, allows obtaining a high-quality image with the minimum exposure dose.

Thanks to an effective cooling system of the X-ray tube assembly, the system provides for a long period of X-ray control, which determines the use of the system for a wide range of diagnostic and medical-surgical manipulations on the heart and vessels. The subtraction angiography mode, the vascular package, the routing, and mask selection option create the necessary conditions for successful use of the system in coronary angiography, angiography, and control of electrophysiology procedures.

A wide range of C-arm movement in all directions including motorized 180° turn in combination with the possibility to move the system throughout the length and breadth of the table without turning the base makes positioning more comfortable and leaves more space for a surgeon. Motorized movements of flat panel detector around its axis without imaging quality loss allows increasing the coverage of the zone of interest thereby enhancing the image information content.

The console for unlocking the C-arm movements and rotations, as well as for panel turning directly on the detector, the control console with imaging mode selection functions, and the real-time dynamic image translation option make the performance of complex procedures comfortable even in case of it being operated by one specialist.

All models of the range have a common platform, common software, and hardware with the single multilingual user interface. This provides for the ease of work and rapid training of the staff, which is particularly relevant when using several systems at one healthcare facility.

If necessary, technical solutions used in the range of mobile C-arm systems allow implementing the remote connection in the online mode to diagnose and remove faults, and also set up the system to meet the user's demands.

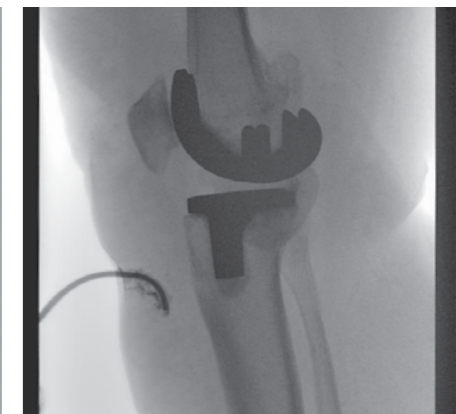
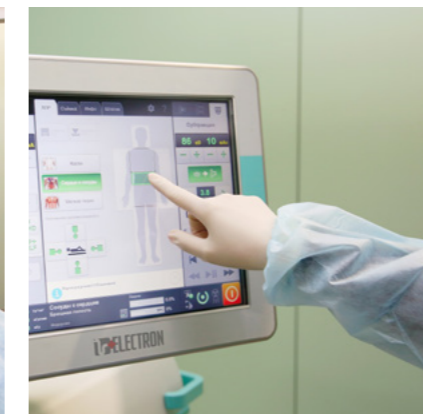

Benefits

Basic configurations*



High image quality

- State-of-the-art digital imaging system
- Automated program filters for image processing
- Wide APR program range
- Removable grid

Mobility and user-friendliness

- Ease of transportation inside and between operating rooms
- Comfortable installation beside a table
- Five degrees of freedom in stand movements
- Motorized C-arm movement including the 180° turn for performing surgical interventions in different positions
- The special wheel design allowing the stand to move in the longitudinal, lateral directions, along the diagonal at selectable angles
- The multi-functional touch control console with the "live" image display option

Multifunctionality

- Long period of X-ray control
- Vascular package
- Digital subtraction angiography (DSA)
- Road Map

Safety and low exposure dose

- Lowered dose fluoroscopy
- Virtual collimation
- Wide APR program range
- Removable grid

Reliability and durability

- Efficient forced cooling system
- High anode heat capacity
- High monoblock cooling rate

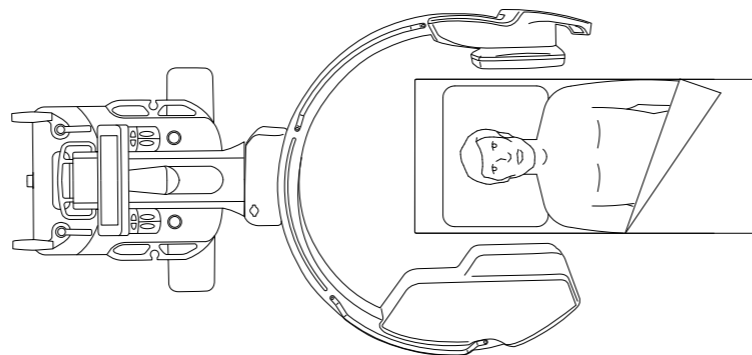

High voltage generator (HVG)

- from 4 kW; from 10 kW; from 15 kW; from 20 kW

X-ray tube assembly with two focal spots

- With fixed anode
- With rotating anode

Digital detectors

- Digital intensifier fluorography unit
- Dynamic flat panel

Software

- Image postprocessing
- Digital subtraction angiography (DSA)
- Vascular package
- Road Map

Additional equipment

- X-ray transparent surgical table
- Automatic injector
- Medical printer
- Clinician's workstations
- Operator's workstations
- Medical monitors
- PACS server

X-ray radiation protective equipment for patients and staff

- X-ray protective clothes for the medical staff
- Personal protective equipment for patients

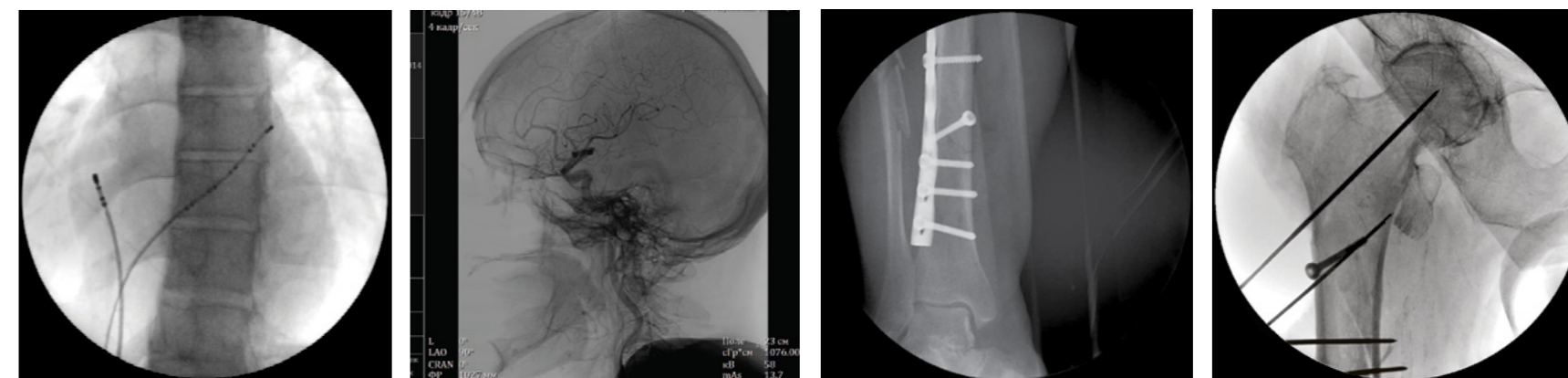

* The "Basic configurations" section includes the information only on the most demanded configurations; the general list is significantly wider. Any configuration and technical parameters can be changed by the manufacturer's initiative or at the customer's request.



Computed
tomography



Innovative R&D product



MODULAR CT UNITS

The modular CT unit is a high-technology, versatile solution developed by the Company's experts within the scope of fighting COVID-19. The equipment is fitted out with all necessary components for emergency CT scans outside the healthcare facility in the mode of a standard computed tomography room. The modular CT unit shall include the following:

- The modular unit for the accommodation of the computed tomography system fitted out with all systems, which are necessary for normal functioning of the CT room
- The computed tomography system 64-slice manufactured by NIPK Electron Co. for primary assessment and differential diagnostics of chest diseases, as well as for revealing concomitant diseases. The modular CT unit can be equipped with a computed tomography system with another slice number as an option. According to the interim methodological guidelines "Prevention, Diagnostics, and Treatment of a new Coronavirus Infection" developed by the Ministry of Health of Russia, a CT scan is considered one of the basic methods of COVID-19 diagnosis.

The key specific feature of the modular CT unit is in the innovation disinfection and ventilation system, which ensures diagnostic imaging safety during the pandemic.

The modular CT unit manufactured by NIPK Electron Co. is a versatile solution providing broad diagnostic possibilities for operating the equipment in both civil and military medicine. The module is fitted out with state-of-the-art engineering solutions ensuring operation in the autonomic mode.

The computed tomography system 64-slice (CT) installed in the module unit is equipped with a wide set of specialized software applications for diagnostic imaging in patients with respiratory disorders, vascular abnormalities, cancer, as well as for assessment of cerebral, renal, and hepatic blood supply. Thanks to this, CT is in high demand not only during the COVID-19 pandemic.

The tomography system is equipped with all modern programs and algorithms to perform examinations with the minimum exposure dose and breath-holding for the shortest possible time. The module shall be transported in a road trailer and installed in any required site; it can be deployed within several hours. The location of the modular CT unit can be changed at any time. If necessary, it can be connected with the main building of a healthcare facility, which allows using it as a permanent CT room.

Introduction of this solution allows the users to:

- Rapidly arrange the operation of a computed tomography room
- Quickly increase the diagnostic capacity of the healthcare facility
- Enhance the throughput up to 12 patients per hour with disinfection after each examination
- Lower the infection risk due to absence of the direct contact between the patients and medical staff

The modular CT unit meets all requirements and standards of the Russian Sanitary Norms and Regulations including those concerning radiation safety of the patients and staff during X-ray diagnostic procedures.

The equipment is supplied with the full document package for obtaining the opinion issued by the local body of the Federal Service for Surveillance on Consumer Rights Protection and Wellbeing in order to commission the CT room.



Benefits

Innovation disinfection system

- For the maximally effective disinfection, two simultaneously operating disinfection systems are provided in the module unit: the aerosol system (spraying the ClO₂ solution through nozzles in the "red" zone) and ultraviolet air recirculation units. After completing a disinfection cycle in the "red" zone, the air is conditioned and dried by a powerful ventilation system, which replaces the air fully and removes moisture left after spraying. It is possible to use the systems in the automatic mode to increase the throughput (the operation frequency is set in advance when commissioning the modular CT unit). CA technician controls the system directly from his/her workstation.

Safety

- The risk of infection of the patients and medical staff is ruled out due to the following:
 - Elaborated patient routing. All rooms of the module unit are divided into the "red" and "green" zones, which exclude direct contact between the patients and the staff. The patients stay in the "red" zone, while workstations of the radiology technician and the radiologist are located in the safe "green" zone
 - Separation of the patient flow to BEFORE and AFTER the examination due to the separate entrance and exit
 - Innovation disinfection system and powerful ventilation system operated in the automatic mode

Mobility

- Delivery of the equipment in an automobile trailer. Possibility to change its location at any time as required

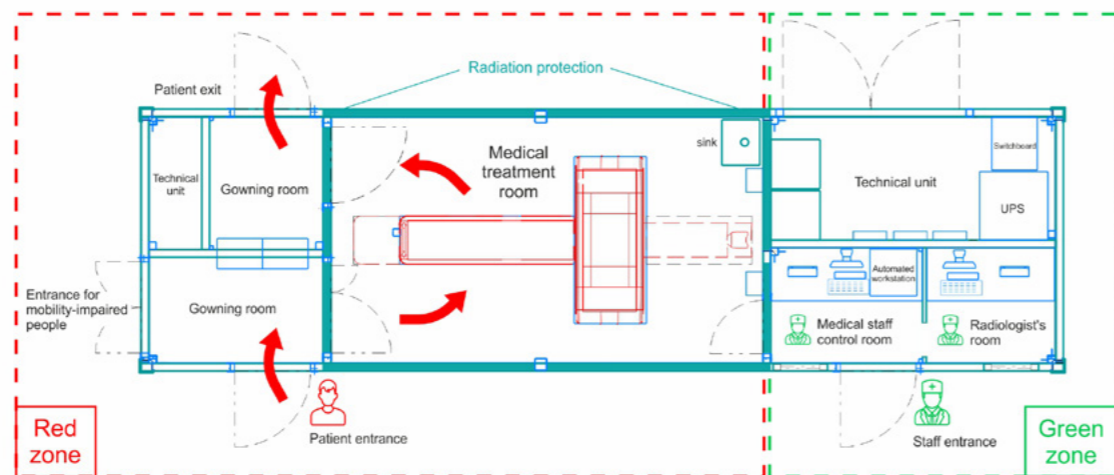

Basic configurations*

Power supply

- Connection to the 380 V external power supply source
- A diesel generator or the central mains
- Uninterruptible power supply 100 kVA for maintaining the equipment operation for 10 minutes in case of a power supply switching off

Climatic system

- Autonomous air heater with rooms distribution and possibility to regulate the heat flow
- Climate monitoring with possible heating
- Convection heaters **OPTION**
- Two simultaneously operating disinfection systems are provided in the modular unit: the aerosol system (spraying the ClO₂ solution) and ultraviolet air recirculation units

Water supply system

- Use of autonomous or central water supply system
- Construction of toilet facilities if the module is operated in the standard regimen **OPTION**

Safety system

- Automatic fire alarm system
- Alert system informing of switching on high voltage in the computed tomography system and room disinfection
- Closed-circuit television systems, loudspeakers, and alert systems covering all module rooms from the control room

Design features

- Enhanced radiation protection around the perimeter of a medical treatment room including doors
- Possibility to perform examinations of mobility-impaired population groups; for their transportation an approach ramp is provided
- Possibility to connect the module with the building of a healthcare facility by constructing a telescopic walkway

Operational conditions

- Operability under different climatic conditions (from +45 to -45 °C)

The innovative R&D product, modular CT unit, is recognized as one of the best ones in the field of effective use of advanced home technologies within the limits of the "Priority 2.0" National Award (2020)



Unit configurations

* The "Basic configurations" section includes the information only on the most demanded configurations; the general list is significantly wider. Any configuration and technical parameters can be changed by the manufacturer's initiative or at the customer's request.

COMPUTED TOMOGRAPHY SYSTEMS



NIPK Electron Co. has been manufacturing state-of-the-art computed tomography systems since 2010. Today, the Company offers a wide range of computed tomography systems from 16 to 128 slices. The advanced intelligent technologies forming the base of the systems allow using the CT systems manufactured by NIPK Electron Co. for all clinical tasks.

The “client first” approach underlying the design of computed tomography systems allows ensuring rapid diagnosis and lower operational expenses.

The patient’s safety and minimization of radiation exposure are the Company’s key priorities in the field of computed tomography. For this purpose, the Company has developed and introduced advanced methods and technologies for lowering the radiation exposure. Special attention is paid to examination of pediatric patients – all computed tomography systems are equipped with specific low-dose protocols for different anatomical regions.

Iterative reconstruction algorithms underlying the computed tomography systems with all slice numbers maximize the diagnostic value of the image obtained at low exposure doses.

The high scanning rate allows analyzing the heart with the high heart rate as well as examining the lungs with a minimum breath-holding period.

The multilingual software makes mastering and using the equipment significantly easier. The component parts included in the computed tomography systems have been selected thoroughly taking into consideration the experience of equipment operation in the Russian real-world practice and are distinguished by their reliability and durability.

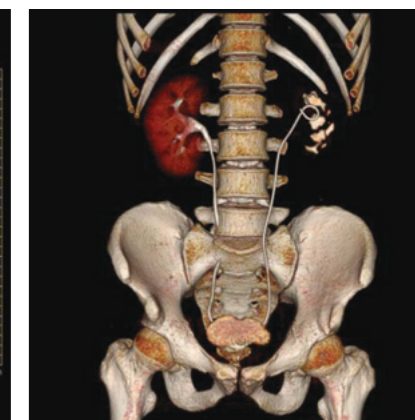
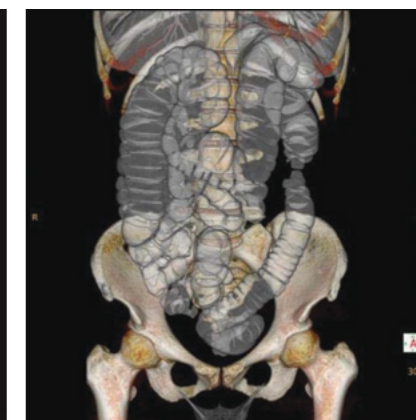
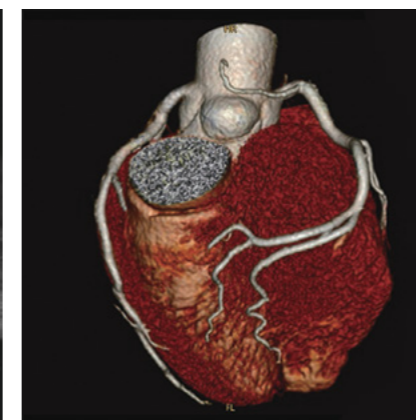
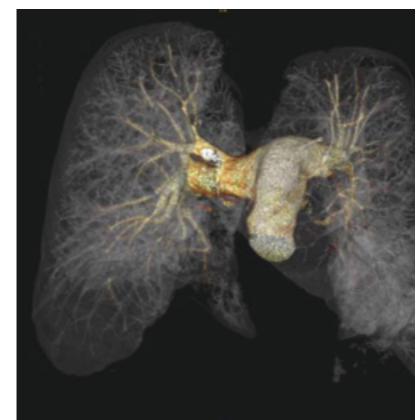

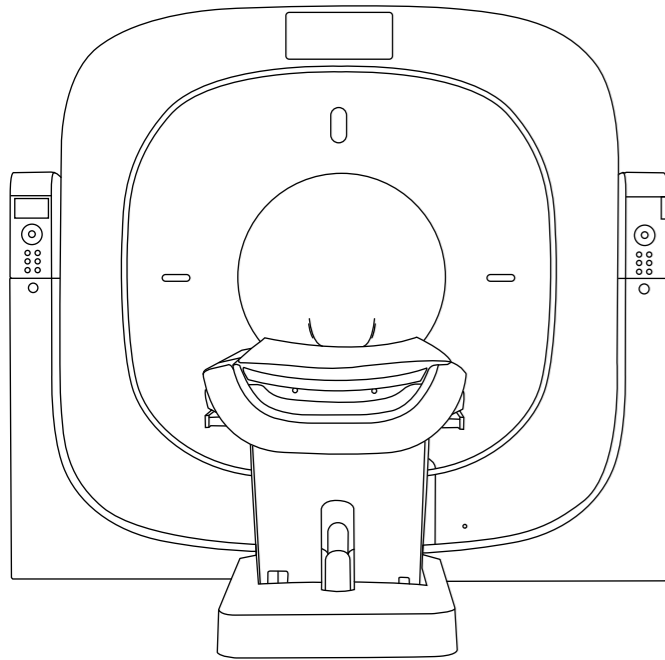

Benefits

- High diagnostic image quality**
 - High resolution
 - Wide range of fields of view for examination of any region
 - The maximum possible pixel number in the acquisition matrix (1024x1024)
 - Metal artifact reduction algorithm
- Easiness, simplicity, and user-friendliness**
 - Modern multilingual software for analysis of examination findings
 - The possibility to integrate the computed tomography system into the information system of the healthcare facility
- Safety and low exposure dose**
 - Special programs for exposure dose reduction
 - Pediatric program modes
- Multifunctionality**
 - Software packages for diagnosing a wide range of disorders
- Reliability and durability**
 - Long service-life of an X-ray tube
 - High-capacity uninterruptible power supply providing for the system operation (gantry and operator's automated workstations) in case of a power outage

Basic configurations*

Detector

- **16 to 128 slices**

X-ray tube heat capacity

- **3.5 to 8 ITUs**

Software packages

- Contrast-enhanced imaging
- Virtual endoscopy, bronchoscopy
- Automatic bone structure highlighting and deletion from the image
- Extended vessel analysis and stenosis assessment
- ECG-synchronized imaging with a cardiac package
- Cerebral and general perfusion analysis
- Lung analysis: search for nodular lesions, pulmonary emphysema analysis
- Virtual colonoscopy
- Automatic calculation of the fatty tissue volume in the abdominal cavity
- Dental package
- Neoplasm segmenting and analysis
- Neoplasm assessment with subsequent identification and localization

Additional equipment

- Radiologist's automated workstations
- PACS server
- Appliances for patient positioning
- Uninterruptible power supply for the gantry and automated workstations
- Single/dual head injector
- Climatic system

X-ray radiation protective equipment for patients and staff

- X-ray protective clothes for the medical staff
- Personal protective equipment for patients
- X-ray protective windows of different sizes

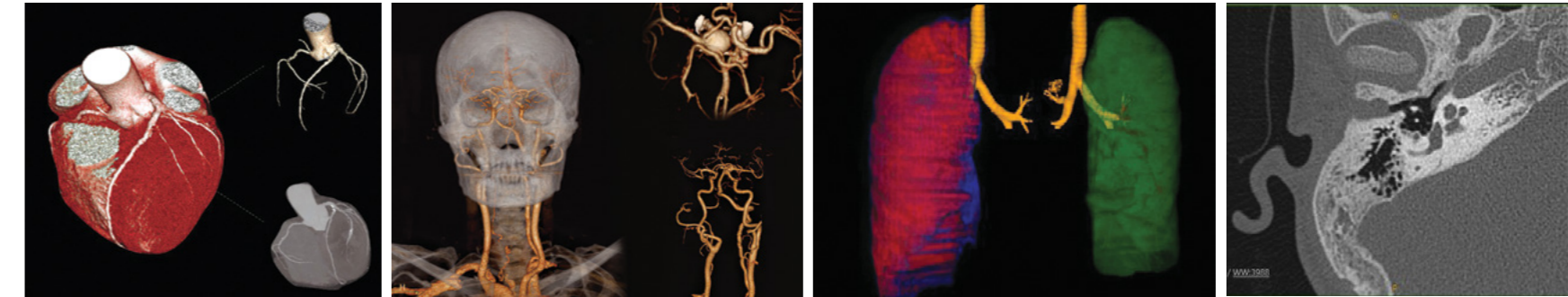
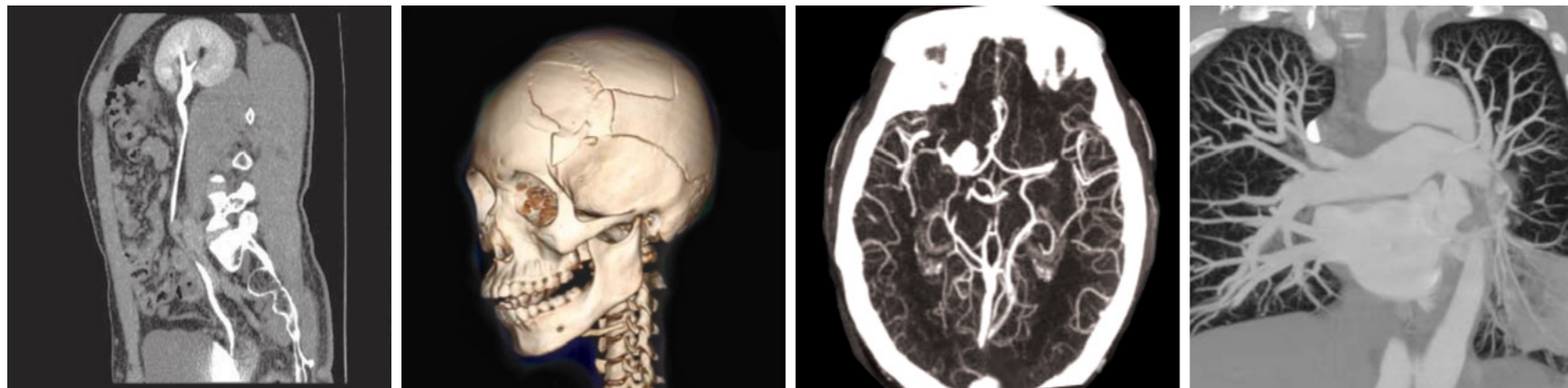

* The "Basic configurations" section includes the information only on the most demanded configurations; the general list is significantly wider. Any configuration and technical parameters can be changed by the manufacturer's initiative or at the customer's request.

WEIGHT-BEARING CT SYSTEMS

FIRST
IN RUSSIA



ATRISS — a compact modern weight-bearing CT system offers a new method for obtaining 3D-images of the foot and ankle joint in an upright position under natural load.

Experts of H.Turner National Medical Research Center for Children's Orthopedics and Trauma Surgery of the Ministry of Health of the Russian Federation have supported the developing of ATRISS which allows performing examinations of both children and adults.

Clinical focus topics:

- Examination of mutual position of the foot joints and ankle joint under natural load
- Examination of patients with flat feet in the upright position with determining true foot bones parameters
- Diagnostics of complex and avulsion fractures
- Diagnostics of tear of the tibiofibular syndesmosis
- Diagnostics of subluxations in the talonavicular joint and other foot joints in patients with complex post-traumatic deformities, the diabetic foot, and the Charcot's foot
- Revealing subluxation and luxation in the metatarsophalangeal and the interphalangeal joints at the time of support in patients with forefoot disorders
- Examinations of the patients with osteochondropathy of the foot

Clinical fields:

- Orthopedics
- Surgery
- Prosthetic care and orthotics of the lower extremities
- Traumatology
- Basic science

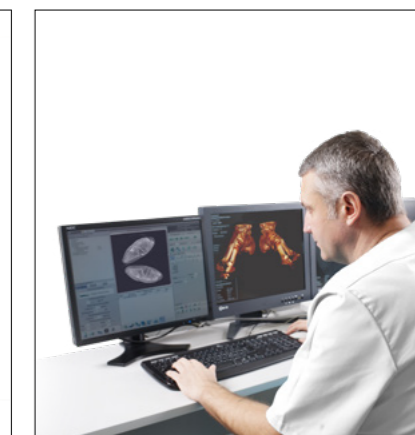

Benefits

- ATRISS provides radiation exposure more than 150 times lower as compared to classical CT systems
- Functional examinations of the lower extremities under natural load
- Possibility to scan a patient in a sitting position in case of complex injuries
- Possibility to perform abstract studies in the field of the foot and the ankle joint orthopedics and surgery
- Maximally accurate post-operative osteosynthesis control
- Maximum efficiency of surgical interventions due to ATRISS state-of-the-art tools for planning osteosynthesis
- Small dimensions and possibility to install the system at any X-ray room without any additional preparation
- ATRISS operates on a 220V power supply
- Minimizing of daily expenses associated with the system operation due to its energy efficiency
- Fast return on investment

Specifications

Patient scanning period	40 s
Reconstruction (preliminary view)	1 s
FOV diameter	430 mm
FOV height	more than 260 mm
Slice thickness	0.25 mm

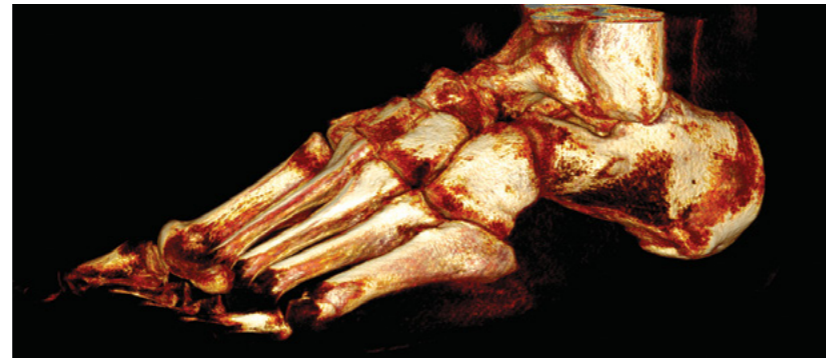
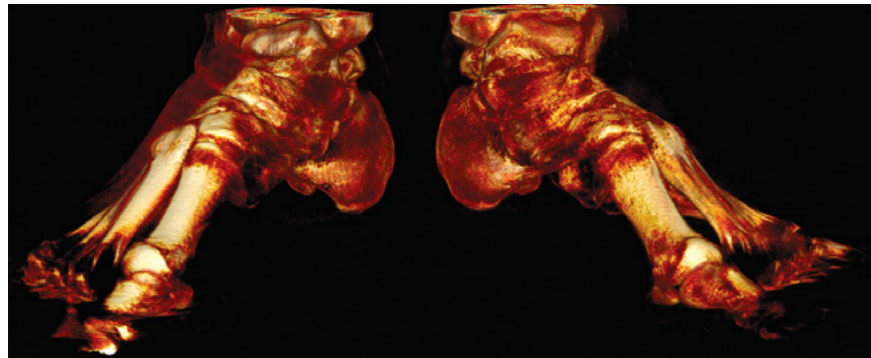

Computed tomography using the ATRISS

Radiography

Computed tomography

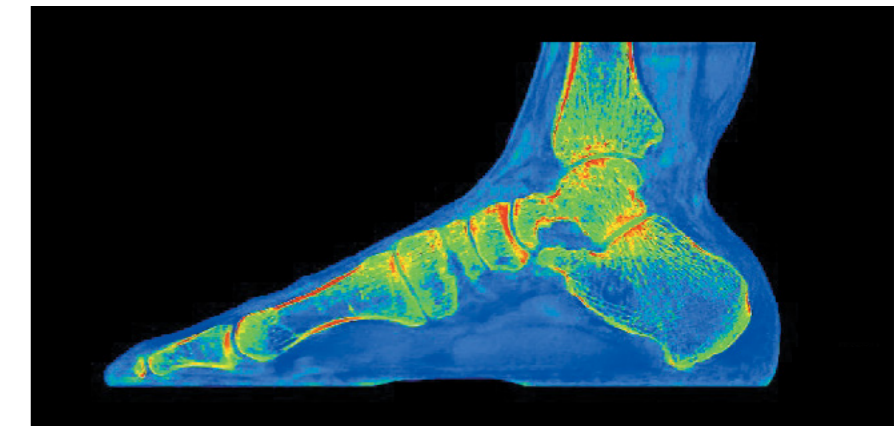
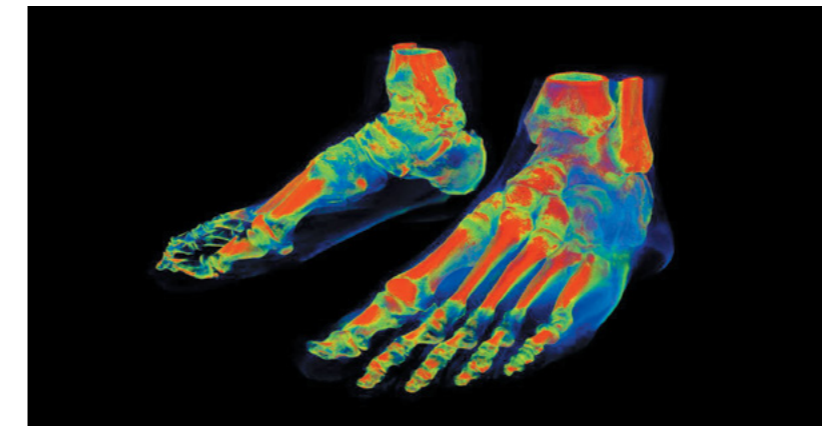

The examination was performed using the ATRISS weight-bearing CT system, patients aged 32 years, post-traumatic pain syndrome

*The section "Specifications" includes information only about the most demanded, according to the rating of requests, versions; the general list is much wider. In addition, any configuration and technical parameters can be changed at the initiative of the manufacturer or at the request of the customer.



Nuclear medicine





SINGLE-PHOTON EMISSION COMPUTED TOMOGRAPHY SYSTEM

NUCLEAR IMAGING SYSTEM



The nuclear imaging system is a versatile dual-detector single-photon emission computed tomography system for examinations of the skeletal bones and internal organs. In the field of nuclear medicine, single-photon emission computed tomography is the most common and popular diagnostic method, which has proven to be useful due to its high quality, affordability, and cost-effectiveness. The method is the most relevant in oncology, cardiology, neurology, endocrinology, nephrology practice, etc.

The nuclear imaging system allows diagnosing diseases at early stages, at the molecular level, revealing both the primary focus and the extent of the process, assessing treatment efficiency, and detecting recurrences. Nuclear imaging systems are widely used and allow investigating various biological processes simultaneously during a single diagnostic procedure.

The nuclear imaging systems have been developed taking into consideration the Russian nuclear medicine practice. Diagnostic procedures can be performed using the entire range of available radiopharmaceuticals. Their production does not require a cyclotron, which ensures their wide availability.

The nuclear imaging systems have the multilingual interfaces and are fitted out with specialized software to analyze the heart, brain, skeleton, liver, kidneys, esophagus, thyroid, parathyroid glands, and other organs. The availability of the combination function of images obtained using the SPECT manufactured by NIPK Electron Co. and computed tomography systems of any other manufacturer will make it possible for a radiologist to determine the localization and the extent of a pathologic process with the highest possible accuracy.

The nuclear imaging system is easy-to-use and user-friendly. The imaging process is fully automated; system initialization is performed by pressing one button. The stand design allows scanning the patient with height of more than 2 m what is of special importance in skeletal bones scintigraphy.

The nuclear imaging system has small overall dimensions, occupies only 6 m², which makes it possible to install it in a room, in which equipment replacement is planned, as well as to establish an isotope diagnostics department even in case of free area deficiency.

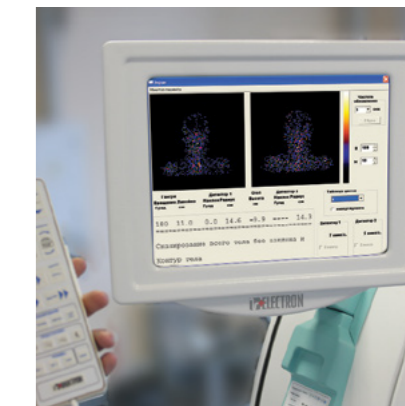

Benefits

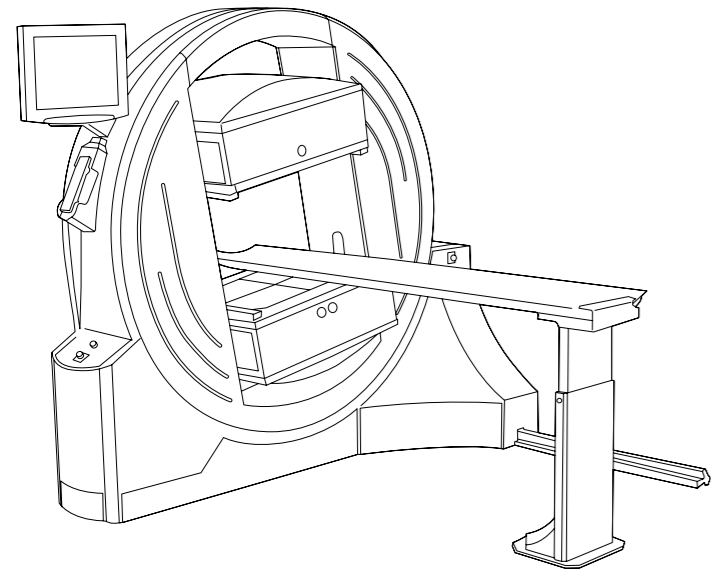

- High diagnostic quality**
 - Highly-sensitive digital detectors
 - Examination result processing and analysis software harmonized with Russian practice
 - Broad collimator nomenclature
- Easiness-to-use and user-friendliness**
 - Multilingual control station interface and software
 - Complete imaging and calibration process automatization
 - Fully automatic patient circuit construction system
 - The use of the entire radionuclides nomenclature of Russian and foreign make
 - Large tabletop height variation range
- Safety**
 - Built-in system control and setup protocols as per standard NEMA NU 1
 - Collision prevention dual-circuit safety system
 - Uninterruptible power supply allowing to complete the examination in case of power shutdown
- Multifunctionality, small size**
 - Examination of the patients in the supine, sitting, and upright position
 - Specialized software to analyze the heart, brain, skeleton, liver, kidneys, esophagus, thyroid, parathyroid glands, etc.
 - Examination types supported: planar (dynamic and static) examinations, SPECT (3D-reconstruction), ECG-synchronized cardiac imaging, whole body examination mode
 - SPECT- and CT-image combination option
 - Small-size and footprint area (6 m²)
- Reliability and durability**
 - Simple mechanical components
 - Low power consumption of the system
 - Power line surge protection

Basic configurations*

- Automated workstations (AWS)**
 - Operator's and radiologist's automated workstations with a specialized software package for image analysis
 - Additional radiologist's automated workstations
 - PACS server
- Collimator set**
 - Low-energy general purpose collimators
 - High-resolution low-energy collimators
 - Medium-energy general purpose collimators
 - High-energy collimator
- Equipment of cardiological examinations**
 - Cardiac synchronization system
 - Cardiovascular machine
- Fitting out of a room and laboratory**
 - Uninterruptible power supply for gantry and automated workstations
 - Climatic system
 - Dose isotope calibrator
 - Equipment for fitting out a laboratory for the work with radionuclides
 - Patient view/position means
- X-ray radiation protective equipment for patients and staff**
 - X-ray protective clothes for the medical staff
 - Personal protective equipment for patients
 - X-ray protective windows of different sizes

NIPK Electron Co. offers the following nuclear medicine systems types:

- Mobile planar gamma-camera with the 25 cm field of view
- Single detector SPECT system
- Dual detector SPECT system
- Three-detector SPECT system for the heart and brain diagnostics

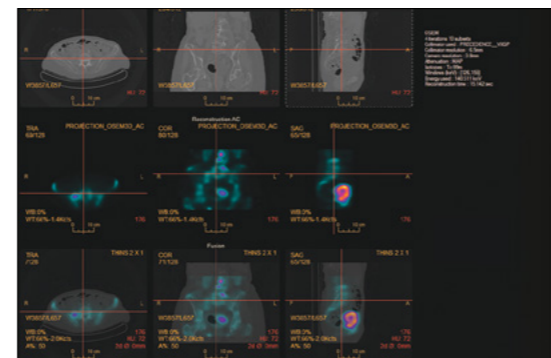
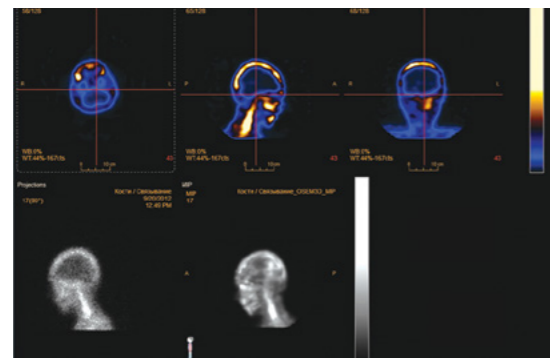
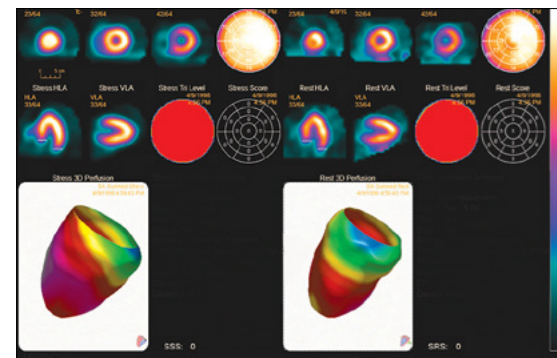
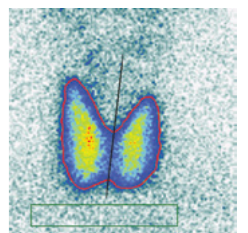
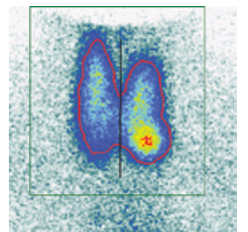

* The "Basic configurations" section includes the information only on the most demanded configurations; the general list is significantly wider. Any configuration and technical parameters can be changed by the manufacturer's initiative or at the customer's request.



**Ultrasound
diagnostics**





ULTRASOUND SYSTEMS



The many-year experience and competencies of NIPK Electron Co. in the field of design and production of medical imaging systems and high-technology equipment allowed designing a wide range of ultrasound systems of different classes: from medium to expert level.

The diagnostic ultrasound systems manufactured by NIPK Electron Co. have a wide scope of application and are intended for abdominal, vascular, cardiology examinations; they are used in pediatrics, neonatology, obstetrics, and gynecology, for assessment of the musculoskeletal system, small and superficial organs, etc.

The scanners of the ultrasound systems range feature the ergonomic design and are fitted out with touch control panels. The systems of high and expert class allow regulating the operating arm and monitoring position for the specialist's comfortable work. The ultrasound system can have probes with different frequency ranges including high-frequency linear probes of up to 18 MHz for certain examination types. The system can be configured both with standard transducers (piezo ceramic transducers) and monocrystalline transducers.

The unique post-processing system of the ultrasound system manufactured by NIPK Electron Co. allows processing data not subjecting it to additional demodulation, which makes it possible to maximize image clarity and contrast.

The software includes the full post-processing image improvement algorithm package aimed at granularity reduction, border enhancement, harmonic imaging, spatial and frequency compounding; the needle visualization improvement function is available for performing a puncture or a biopsy.

The ultrasound systems produced by NIPK Electron Co. support all data acquisition modes: B- and M-mode, color doppler, pulse wave doppler, power doppler and power-directed doppler, and tissue doppler. The data can be presented in duplex and triplex modes.

The software can also include echo-contrast agent packages, elastography, real-time image volume reconstruction, panoramic view. The images obtained using the ultrasound system and protocols can be saved on USB, DVD, shared via Wi-Fi and Bluetooth.

Any system can be configured with different programs and transducers for specific tasks — for cardiology, examinations of the musculoskeletal system, gynecologic examinations, performing interventional operations under ultrasound supervision.

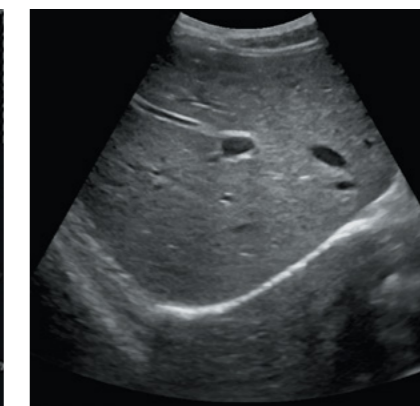
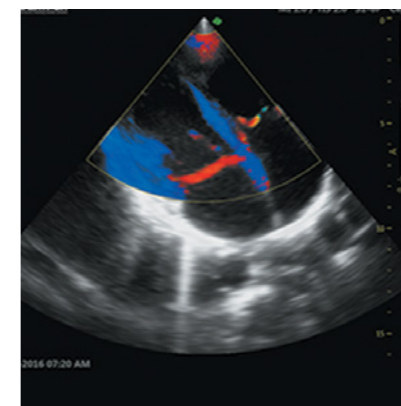

ULTRASOUND SYSTEMS

High diagnostic image quality

- High image clarity and contrast
- Higher sensitivity of doppler imaging
- Real-time high data processing rate
- State-of-the-art analysis of examination findings
- Automated program filters for image quality improvement

Easiness, simplicity, and user-friendliness

- Touch control panel in all scanners
- Specialized rubberized holders for reliable transducer fixation
- User-friendly multilingual interface
- Possibility for examination result transfer to all types of external media (USB, DVD, external HDD)
- Data transfer via Bluetooth, LAN, Wi-Fi
- Sending images to the PACS
- DICOM image option

Mobility and multifunctionality

- Adjustment of the arm position (height along and in a horizontal plane)
- Monitor position adjustment
- From 4 to 5 transducer ports depending on the system class
- Gel heating function
- A wide transducer range including monocrystalline ones

Reliability and durability

- Elaborated, simple, and reliable system design

Specialized software packages

- All types of dopplers (CFM, PWD, PDI, TD, CWD, TVI, TVM)
- M-Mode, Anatomical M-Mode, Color M-Mode
- Cardio package with ECG-gated image acquisition
- Vascular package
- Obstetrics and gynecology package
- Pediatrics and neonatology package
- Kidney analysis package, urological package
- Panoramic view
- All modes of volume reconstruction (3D/4D)
- Contrast-enhanced imaging option
- Elastography
- Needle visualization improvement function for performing puncture or biopsy
- Implemented automatic measurements for various organs and systems

Additional equipment

- Image printer
- Uninterruptable power supply for the scanner
- Footboard set for scanner control
- PACS server

Benefits

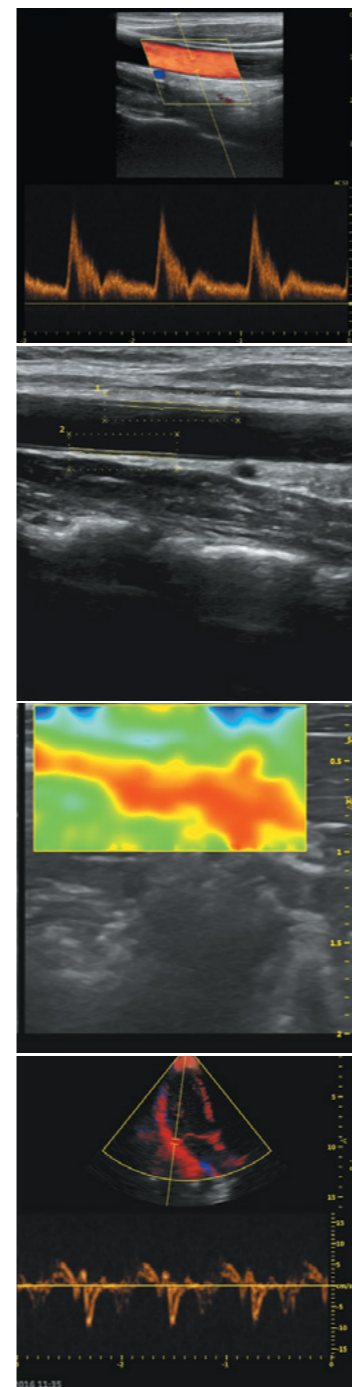

All latest technologies in different class systems*

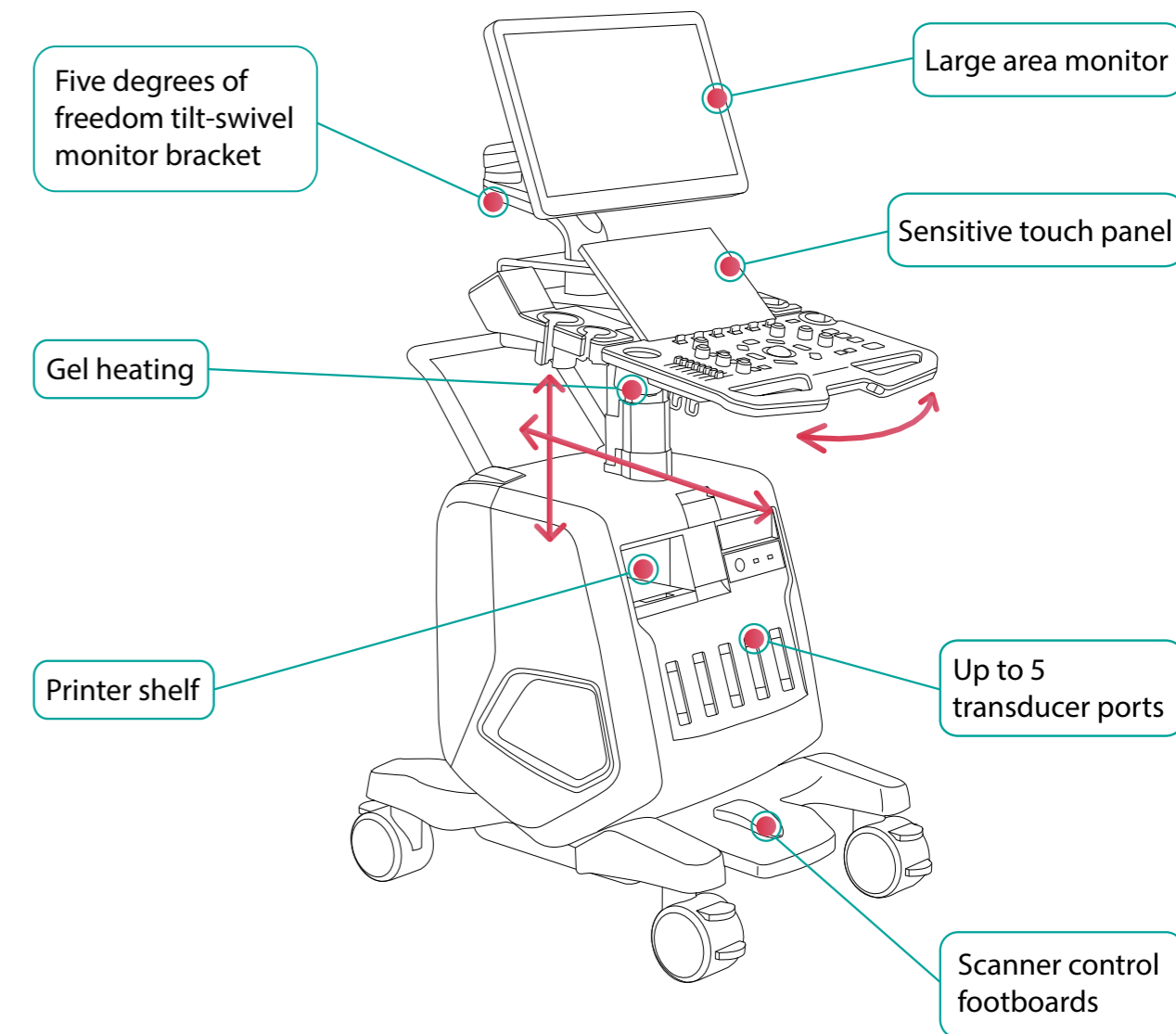

* The ultrasound systems manufactured by NIPK Electron Co. can be configured with different transducer types, specialized software packages, and periphery equipment. Technical parameters of the system can be changed by the manufacturer's initiative or at the customer's request.



IT solutions for healthcare





IHE Integrating the Healthcare Enterprise

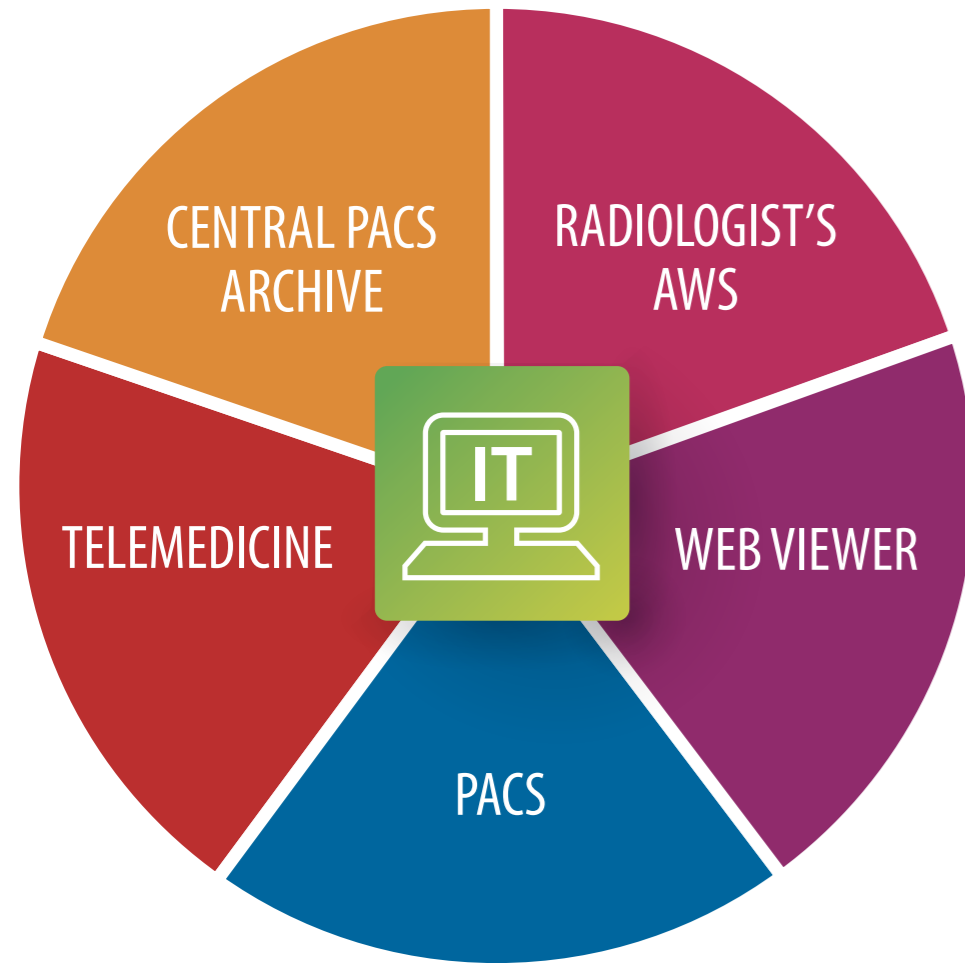

The products of NIPK Electron Co. include solutions for informational support of the clinical diagnostic process*

Russian invention

- Designed together with healthcare professionals
- Registered in the Russian software registry and also in the state register of medical products
- Full compliance with the requirements of the Ministry of Health of the Russian Federation, Ministry of Digital Development, Communications and Mass Media of the Russian Federation, international (DICOM, HL7, IHE), information safety requirements (FZ-152)
- Cross-platform (Windows, Linux, MacOS); free software (FSW) use
- Integration of various vendors and modalities equipment

* The solutions can include a product combination or consist of individual components

MULTI-LEVEL TASKS FOR THE HEALTHCARE SYSTEM

For the region and healthcare facilities

- Reduction of mortality level and increase of the lifespan due to early revealing of diseases, quality and accessibility improvement of medical services
- Medical care optimization
- Enhancement of economic efficiency including that due to the reduction of the following:
 - Cost for treatment of diseases at earlier stages and the number of duplicate examinations
 - Prime cost of diagnostic examinations due to saving the expensive consumables
 - Expenses for medical data storage due to its centralization
- Establishment of generally specialized expert centers (cancer/tuberculosis/vascular centers, etc.)
- Reduction of the time for rendering medical services
- Overcoming a deficit of healthcare professionals, organization of training, research works, and advanced training
- Generating the patient examination history and providing access to it to healthcare professionals from other healthcare facilities
- Generating the patient's electronic medical card including results of diagnostic examinations
- Uniting the diagnostic equipment in the single information space
- Storage of examination data in one place which is accessible for all specialists

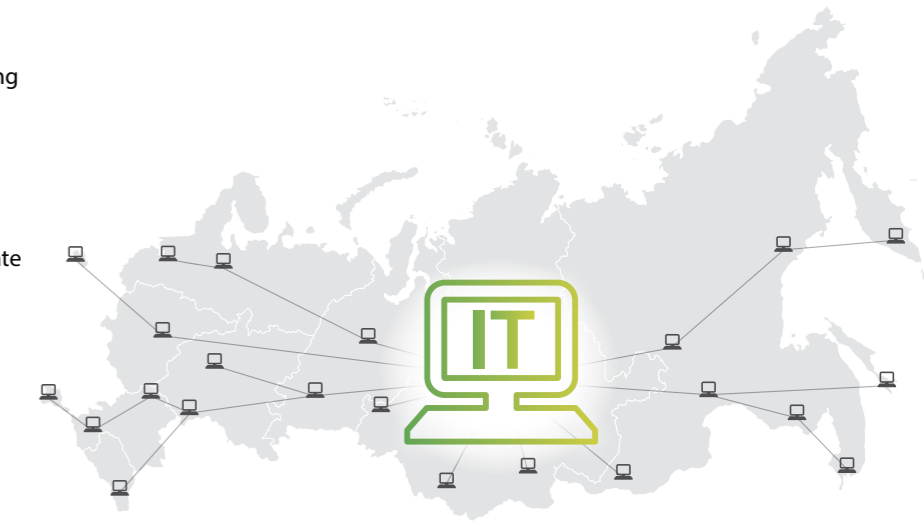

- Providing radiologists access to medical examinations from any automated workstation
- Control and optimization of the expensive equipment and staff loading
- Generation of the statistical database for analysis and making strategical and tactical solutions

For patients

- Availability of highly-qualified medical aid in remote regions, saving health, improvement of life quality and lifespan
- Reducing the number of duplicate examinations and the exposure dose for the patient

- Reducing the total cost of medical services due to the possibility of early revealing of diseases and also decrease of transport expenses for visiting central healthcare facilities
- Saving time

DATA COMMUNICATIONS SYSTEM PACS

The PACS software and hardware system developed by NIPK Electron Co. is designed for reliable and safe storage of medical images and data. The system allows combining digital diagnostic equipment of various manufacturers and generating unified image archives. The access to images of diagnostic quality can be obtained from any operator's automated workstation connected to the system, including remote access, using "Thin client" workstations (based on the Web Viewer web client).

The integrated innovative solution of the Company allows considerable enhancement of the efficiency of use of digital diagnostic systems, diagnostics quality, and timeliness.

Functionalities

The system provides for storage and transfer of medical data obtained as per DICOM protocol from the following modalities:

- Digital radiography (DX)
- Computed radiography (CR)
- Linear computed tomography (DX, CR)
- Radiofluoroscopy (RF)
- Mammography (MG)
- Computed tomography (CT)
- Magnet resonance imaging (MR)
- Angiography (XA)
- Positron emission tomography (PET)
- Ultrasound (US)

Contains all the tools necessary for working with images for radiologists and clinicians.

Provides for a possibility to view, process, and analyze different modality images at a single operator's automated workstation. Allows generating protocols and consultations for the examination in electronic form. Provides protected web access to images of diagnostic quality via any standard web browser (based on HTML 5).

Provides for simple and fast search of the patients and examinations by different parameters. Allows sending images to specialist radiologists for consultation. Makes it possible to record a medical disc for viewing using any computer, as well as to print images, protocols, and consultations using medical or office printers.

The configuration can include radiologist's and clinician's automated workstations. Radiologists' automated workstations can be fitted out with color medical high-resolution monitors providing for image quality required for diagnostics.

An additional office monitor allows working with the examination log and electronic protocols reducing the visual load.



CENTRAL PACS ARCHIVE

The Central PACS Archive established by NIPK Electron Co. is an integrated solution based on independent PACS system components. It is intended for medical data management at the regional level.

The Central PACS Archive is an innovative product allowing to establish a unified diagnostic network in the region by connecting the diagnostic equipment, as well as the PACS and operator's automated work stations of different manufacturers, thereby creating conditions for internal process optimization at healthcare facilities and quality improvement of medical aid provided to the patients.

The main objective of the Central PACS Archive is to aggregate, organize and unify the storage of medical data obtained from various sources at the regional scale.

The Central PACS Archive established by NIPK Electron Co. provides for

- Obtaining and storage of diagnostic examination findings from the diagnostic equipment and the PACS of different manufacturers supporting DICOM 3.0
- Guaranteed access to stored medical data under conditions of unstable communication, poor communication channels
- Generating archives of different levels, storage of large data sets with the minimum costs
- Keeping the diagnostic examination result history
- Unique patient identification
- Providing access to diagnostic examination findings with diagnostic quality using a built-in Web Viewer based on HTML 5 from any radiologist's automated workstation
- Medical data security
- Providing statistical data to check the diagnostic equipment loading, the number of examinations performed
- Interaction with external information systems (Medical information system/Regional health information system/Integrated electronic medical card)

The Central PACS Archive established by NIPK Electron Co. helps arrange the following

- Remote tele-radiological consultations using diagnostic examinations which are stored at the Central PACS Archive
- Specialized expert centers
- Screening examinations for different disorders
- Rapid and effective medical data (pictures and examination protocols) exchange (in the electronic form)

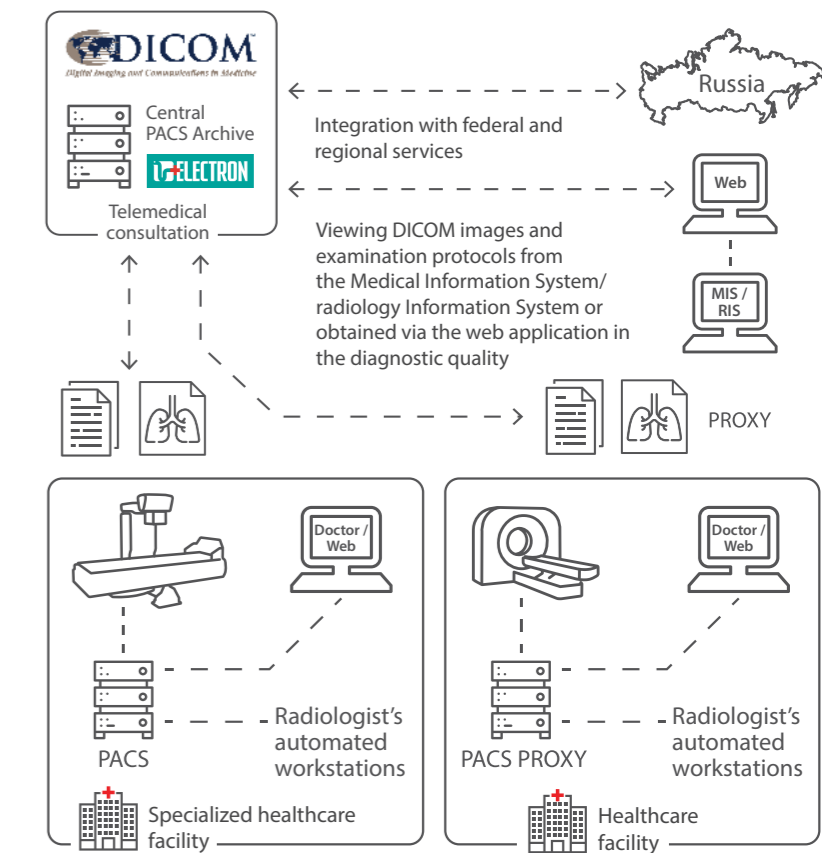

MEDICAL SCREENING. DOUBLE READING/SECOND OPINION PROCESSES AUTOMATION

This service allows generating additional expert medical conclusions basing on the examinations performed and prepared protocols.

Firstly, all examinations are assessed and described by a radiologist. After making up the primary opinion, the examination findings may be sent for coordination to an additional expert who shall confirm or supplement the primary radiologist's opinion.

Remote descriptions and consultations

The service makes it possible to perform remote consultations and generate opinions based on the examination findings from the time of generation of a request for a consultation with the attachment of the required patient's medical data, planning, and routing of the request to generation of consultation results.

Remote consultations are particularly relevant for regions with poor transport accessibility, deficiency of qualified staff if it is necessary to send the patient's data for consultation to the healthcare facility of the higher level or consult another expert doctor.

Equipment loading factor analysis and control

The possibility to track, plan and redistribute patient flows to diagnostic examinations; planning maintenance, repair, and replacement of the equipment.

The possibility to collect, view and analyze the equipment data. Generation of statistical reports using adjustable templates. Efficiency analysis of the use and loading of the high-technology diagnostic equipment.

MULTIMODALITY DIAGNOSTIC RADIOLOGIST'S WORKSTATION (RADIOLOGIST'S AWS)

An automated workstation is designed for providing the work of specialists analyzing and describing the results of diagnostic examinations and, if necessary, clinicians who use diagnostic imaging findings to make clinical decisions.

The radiologist's AWS can be configured as a "thick client" (a separate workstation) or as a "thin client" (based on the web client), via Web Viewer.

Software functions

- The work with examinations from various modality equipment
- Search for necessary medical information in open medical data storage sources
- Viewing the patient and examination data
- Viewing and analysis of images including CT, MRI, US, ECG, angiography
- The work with examination protocols: generation, double reading, export, and other necessary actions
- Generation of image hard copies (printing)
- Preparation of medical discs for their handing-over to the patients (at request) and other participants of the clinical diagnostic process
- Availability of different specialized clinical packages

Web Viewer benefits

- Installation at workstations is not required, which means low requirements for PC hardware
- Interface adjustment for a specific user
- Flexible search for information
- The work with several examination sources
- Obtaining medical data with diagnostic quality
- Analysis and description of examinations

COMPLETED PROJECTS

Unified Information Diagnostic Space. Moscow Region



IT solutions for healthcare

Objective: to improve the efficiency of the medical and diagnostic process, lower mortality, increase the lifespan

Basic tasks

- Ensuring efficient loading factor of expensive equipment
- Establishment of the expert center at the Moscow Regional Research and Clinical Institute («MONIKI») including remote consultations and double reading
- Generating the patient examination history and providing access to it to radiologists from other healthcare facilities

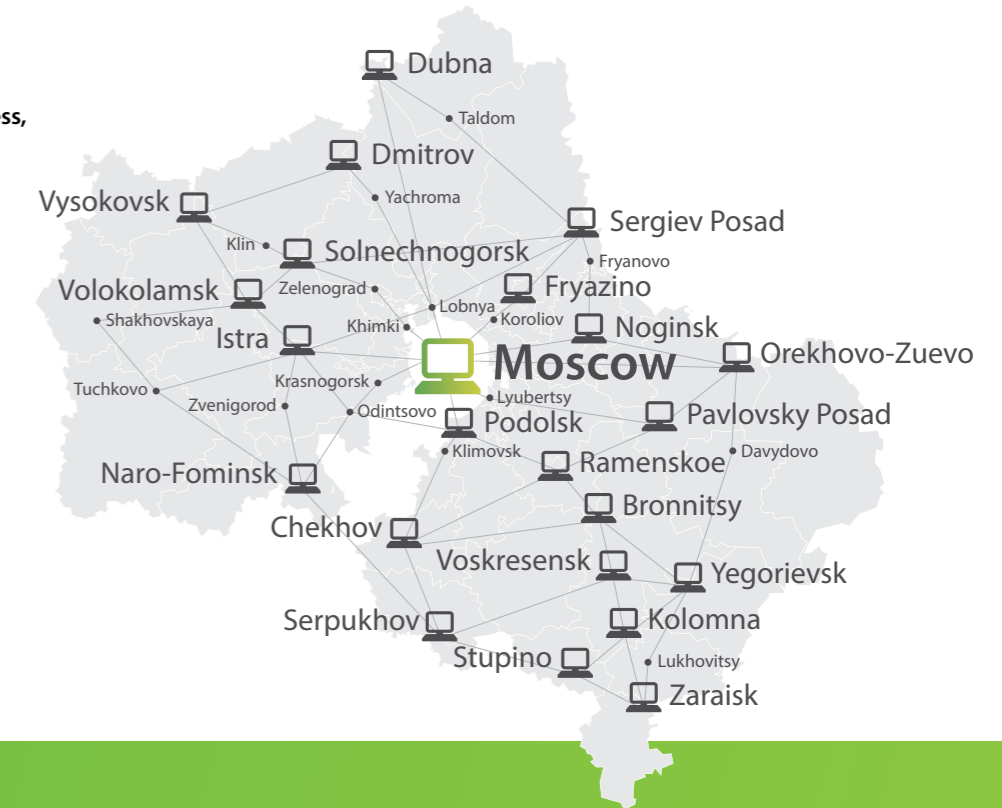

Results of project implementation

More than 200 diagnostic systems from different manufacturers at 63 structural subdivisions of 53 healthcare facilities of the region have been united in the unified information space

More than 200,000 opinions were issued during the project implementation. The experts of the Institute submitted correcting conclusions in 36% of cases

The equipment loading increased from 45% to 94%

The examination waiting time reduced from 26 to 9 days

The conclusion is received in not more than 24 hours

COMPLETED PROJECTS



Arrangement of mammography screening basing on the Central PACS Archive of NIPK Electron Co. Saint Petersburg

Objective: to lower mortality/disability, improve the timeliness of revealing and treatment, optimize processes, analyze and control the equipment loading/efficiency of use, save budget funds

Basic tasks

- Uniting the mammography systems from different manufacturers (43 systems at 38 healthcare facilities of the region) in the unified information space
- Centralized collection and storage of medical data, i.e., pictures and primary examination protocols obtained from connected healthcare facilities taking into consideration narrowband communication channels
- Granting access to medical data and a possibility of double reading of screening examinations by the employees of the expert center
- Development of screening regulations

Process description

- The screening examination is performed using mammography systems located at healthcare facilities
- The examination findings are saved in local PACS of the healthcare facility
- The local PACS transfers automatically the examination findings to Saint Petersburg Central PACS Archive. In case of narrow communication channels or communication break, the PACS operates in the proxy mode, i.e., transfers data at the time of recovery or minimum loading of the channel
- A radiologist of the healthcare facility performs the primary analysis and the first reading of screening examinations
- When the examination findings are saved at the Saint Petersburg Central PACS Archive, they become available for an expert of the Saint Petersburg State Budget-funded Health Institution City Clinical Oncology Center generating the set of examinations and performing the double reading (making up of the second opinion)
- A radiologist of the healthcare facility sees the expert conclusion. If necessary, the patient is referred for an additional examination

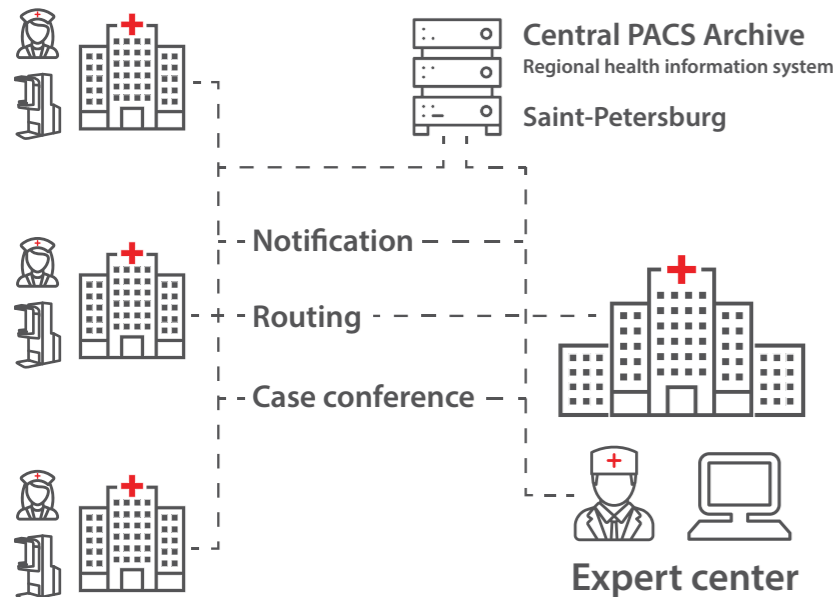

Results of project implementation

It allows revealing additionally more than 2% of breast cancer cases at stage 1 and 2 annually

Potential annual budget economy: 2016: RUB 203.5 mln, 2017: RUB 260 mln

Advanced professional training of the medical staff

Establishment of a tuberculosis diagnostic cluster. Vladimir Region

Objective: to lower mortality/public health hazards, ensure early diagnosis and treatment, optimize processes under conditions of staff deficiency, analyze and control the equipment load/ efficiency of use, save budget funds

Basic tasks

- Uniting the X-ray systems of tuberculosis departments of the cities of Vladimir, Kovrov, Murom in a unified information space based on the Tuberculosis Treatment Center
- Granting access to medical data to radiologists of regional departments
- Arrangement of remote consultations, second opinions

Results of project implementation

The problem of qualified radiologists deficiency has been overcome due to implementation of remote viewing and description of examinations by available radiologists

Reduced tuberculosis-related mortality rates (2015 – 4.9; 2017 – 3.7 per 100,000 population)

Decreased prevalence of tuberculosis (from 46.2 to 38 per 100,000 population)

Arrangement of the patient's unified diagnostic card. XXI Century Private Clinic

Objective: to improve the efficiency of the medical and diagnostic process and use of human resources

Basic tasks

- Uniting the X-ray and ultrasound systems of 14 geographically distributed branches in a unified information space
- Providing radiologists access to medical data from any automated workstation
- Arrangement of remote consultations/case conferences

Results of project implementation

Territorial centralization of radiologists in the main building, which allowed optimizing and use more effectively the clinic resources

Generation of the patient's unified diagnostic card regardless of the place of visit. Rapid decision-making in difficult cases

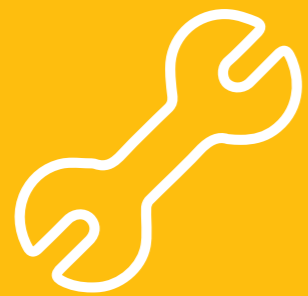

Service



COMPANY OF RAPID SERVICE RESPONSE

While properly understanding the customer's needs, responsibility, and importance of the work, NIPK Electron Co. guarantees high quality of service, user-friendliness of the equipment, rapid and efficient solving of the tasks set.



MORE THAN 20 YEARS ON THE MARKET OF SERVICE SUPPORT IN RUSSIA

The accumulated experience, a significant base of knowledge, and unique competencies in the sphere of service support



MORE THAN 40 SERVICE SUPPORT ENGINEERS

One of the biggest teams of highly qualified professionals on the Russian market providing services for installation, repair, and maintenance of the medical equipment

The service department of NIPK Electron Co. is:

- Professional servicing, training, and assistance in all regions of the Russian Federation and CIS countries
- The well-established remote diagnostics system allowing to solve several problems of the customer within few hours without visiting the healthcare facility
- Online consultations on the issues of equipment operation available at any time
- Continuous advanced training of service engineers
- Complete stock of spare parts, accessories, and component parts allowing to minimize the repair time
- Involvement of the work of reliable service partners in different regions of the Russian Federation if necessary

The service department of NIPK Electron Co. is a team of professionals, whose task is to create conditions for the maximally effective and convenient use of the equipment at healthcare facilities, as well as to enhance availability, and improve the quality of medical care.

NIPK ELECTRON CO. IS YOUR RELIABLE PROFESSIONAL PARTNER





Saint-Petersburg

phone: +7 (812) 325-0202

fax: +7 (812) 325-0444

e-mail: omb@electronxray.com

Moscow

phone: +7 (495) 935-7785

electronxray.com